

## DOCUMENT RESUME

ED 439 050

SO 031 229

TITLE Oregon Trail Teacher's Guide.  
INSTITUTION National Park Service (Dept. of Interior), Washington, DC.  
PUB DATE 1999-00-00  
NOTE 135p.; For another document from the Whitman Mission NHS, see SO 031 228.  
AVAILABLE FROM Whitman Mission National Historic Site, Route 2, Box 247, Walla Walla, WA 99362-9699. Tel: 509-522-6360. For full text: <http://www.nps.gov/whmi/ortrtg.htm>.  
PUB TYPE Guides - Classroom - Teacher (052)  
EDRS PRICE MF01/PC06 Plus Postage.  
DESCRIPTORS Cultural Differences; Ethnic Groups; Field Trips; Geographic Regions; Heritage Education; Historic Sites; \*Integrated Activities; Primary Sources; Secondary Education; Social Studies; \*United States History  
IDENTIFIERS \*Oregon Trail; Westward Movement (United States)

## ABSTRACT

The road to the U.S. West, known as the Oregon Trail, had its first real traffic in 1843 when a group of about 1000 people left Independence, Missouri and traveled west. This teacher's guide contains short descriptions of the main landmarks and stopping points that were significant along the northwest portion of the Oregon Trail. The guide is primarily devoted to the geographical areas and peoples found around and about these important locations. It is divided into the following sections: (1) "Historical Highlights"; (2) "Indians/The First People in Oregon"; (3) "The Missionaries"; (4) "The Pioneers"; (5) "Social Studies Activities"; (6) "Map Activities"; (7) "Language Arts"; (8) "Science Activities"; (9) "Math Activities"; (10) "Art Activity Suggestions"; (11) "Physical Education Activities"; and (12) "Appendix." A Teacher's Guide Evaluation Form is attached. (BT)

# OREGON TRAIL TEACHER'S GUIDE

Whitman Mission National Historic Site  
Rt. 2, Box 247  
Walla Walla, WA 99362-9699

<http://www.nps.gov/whmi/ortrtg.htm>

1999

U.S. DEPARTMENT OF EDUCATION  
Office of Educational Research and Improvement  
EDUCATIONAL RESOURCES INFORMATION  
CENTER (ERIC)

- This document has been reproduced as received from the person or organization originating it.
- Minor changes have been made to improve reproduction quality.

BEST COPY AVAILABLE

- ° Points of view or opinions stated in this document do not necessarily represent official OERI position or policy.

# OREGON TRAIL TEACHER'S GUIDE

## TABLE OF CONTENTS

### **Section One - Historical Highlights**

The Oregon Trail

Oregon Trail Northwest Landmarks

Soda Springs

Fort Hall

American Falls

Three Island Crossing

Fort Boise

Farewell Bend

Flagstaff Hill

Whitman Mission

Most Frequently Asked Questions About the Whitman Mission

The Dalles

Barlow Road

Most Frequently Asked Questions about the Barlow Road

Fort Vancouver

Oregon City

### **Section Two - Indians/ The First People in Oregon**

Prehistory of Oregon

Indian Children

Indian Tribes of Oregon

General Information

Cayuse, Umatilla, and Walla Walla Indians

Nez Perce Indians

Map - Indian Tribes of the Northwest

The Seasonal Cycle

Indian Trade Network

Tule Mat Long House

Eastern Oregon Winter Dwellings

### **Section Three - The Missionaries**

### **Section Four - Pioneers**

## **Section Five - Social Studies Activities**

- Compare and Contrast
- The First People in Oregon
- Comparing Indians of the Northwest
- Fur Trappers and Traders
- Mountain Men
- Go West!!
- People on the Trail
- The Inland Fur Trade Company
- Pioneer Life
- The Missionaries
- Oregon Trail -- Wagons Westward
- Fort Vancouver -- The Inland Fur Trade
- Discover the Columbia River!

## **Section Six - Map Activities**

### **Section Seven - Language Arts**

- Writing
- Do We Go, Or Stay?
- Sign Language on the Plains
- Literature
- Spelling Activities

### **Section Eight - Science Activities**

- Geology
- Soils
- Health
- Seasons
- Agriculture
- Wildlife Biology
- Science Activities

### **Section Nine - Math Activities**

- Oregon Trail Math
- Jack's Math Activities

### **Section Ten - Art Activity Suggestions**

- How to Build a Fort
- Paul Kane Sketches
- Constructing a Raft Diorama
- Building a Covered Wagon #1
- Building a Covered Wagon #2
- Indian Moccasins
- Making a Patchwork Quilt Arts & Crafts Activities

## **Section Eleven - Physical Education Activities**

### **Section Twelve - Appendix**

#### **Pioneer and Indian Recipes**

Hardbread Biscuits

Beef Jerky

Indian Fry Bread

Narcissa's Camp Bread

Sarah Smith's Meat Pie

Sarah Smith's Buffalo Gravy

Tea Biscuits

Potato Pudding

Apple Treat

Apple Snow

Cranberry-Nut Muffins

#### **Oregon Trail Books**

Audio-Visuals Available for Loan to School Groups

Organizations and Agencies along the Oregon Trail (Idaho-Washington-Oregon)

### **Teacher's Guide Evaluation Form**

# OREGON TRAIL TEACHER'S GUIDE

## SECTION ONE - HISTORICAL HIGHLIGHTS

### THE OREGON TRAIL

The Oregon Trail was the highway to the future for many of those who traveled it. They hoped it would lead to a better life, more fertile land, and a chance to control their own destiny. For many these hopes and dreams were fulfilled, for some the dream died, the highway was filled with danger, hardships and tragedy. The road to the west, known as the Oregon Trail, had its first real traffic in 1843 when a train of about 1000 people left Independence for the west. Marcus Whitman traveled with this group of emigrants, helping to guide them across the great plains. The trail was used the heaviest until the mid-1860's, when traffic began to dwindle.

The road basically followed the Platte River. To the north lay the Rocky Mountains, to the south, desert. The Platte offered a central corridor to those heading west, first up the Platte, then the North Platte to the Sweetwater which led them to south Pass. From there by way of the Snake or Humbolt Rivers to reach the Pacific coast.

The Independence and St. Joseph, Missouri areas were the most common starting places. Folks gathered there in large numbers before heading out towards the west. This was the place to make sure your "outfit" was fully assembled and equipped. While television has led many to think the emigrant wagons were pulled with horses, the truth is oxen were the number one draft animal of the great migrations. About 80% of the wagons in 1850 were hauled by these creatures. Horses were expensive, about \$200 for a medium quality one and their upkeep was demanding. A horse would not eat the dried grasses of the plains and he was bothered with insects, and the tepid water of the Platte gave him distemper. Horses were used only by those outfits well enough off to be able to carry grain for them.

Mules were tough and durable, and better able to survive the plains' dry feed and water, but at times their temperament was given to mayhem! They were often used for pack trains, but diaries are filled with the troubles caused by contrary mules. Oxen, on the other hand, were adaptable and calm. They survived on the dried prairie grasses. The Indians did not steal them as they would horses or mules. Oxen were also much cheaper, at \$50 to \$65 per head. It was recommended that oxen be not less than five years old. A wagon needed at least two span, or pair, of oxen to pull it and if possible, a spare pair should be taken. Oxen hooves required attention, and shoes were applied to their feet to protect them. If iron shoes were not available, emigrants nailed sole leather on or smeared the hooves with tar or grease and fastened on boots made of buffalo hide. Families had great affection for their oxen, giving them names like Brindle

or Bright. When one died, the whole family grieved.

Wagons used on the Oregon Trail were not the boat-shaped Conestoga, but more of a farm wagon, capable of hauling from 1600 to 2500 pounds. It was protected with bows reaching about 5 feet above the wagon bed and covered with some type of heavy, rain proof canvas-like material. Spare parts, tongues, spokes, and axles were carried, often slung under the wagon bed. Grease buckets, water barrels, heavy rope (at least 100 feet was recommended), and chains completed the running gear accessories. When store-bought grease, necessary for wheel bearings was exhausted, boiled buffalo or wolf grease served the purpose. Provisions were of vital importance to the emigrant. The work was hard, so foods high in calories were favored. The food supply was the heaviest and most essential part of the covered wagon cargo.

A delicate balance was necessary, for hauling too much food would wear down the animals, but not enough could result in starvation. While some wild berries, roots, greens, and fish might supplement the diet, it was too risky to depend on these. It was also not a good idea to depend on too much success in hunting or foraging on the semi-arid and thinly covered high plains. Prior to 1849 there were no stores or respectable trading posts along the routes, and even after the establishment of the post at Scott's Bluff, and at the Army quartermaster posts at Fort Kearny and Ft. Laramie, supplies were meager and extremely high priced.

It was recommended by those who wrote early guide books that each emigrant be supplied with 200 pounds of flour, 150 pounds bacon, 10 pounds coffee, 20 pounds sugar and 10 pounds of salt. Basic kitchen equipment consisted of a cooking kettle (dutch oven), fry pan, coffee pot, tin plates, cups, knives and forks. Stoves were a help, but the smaller the better. Bread-bacon-coffee was the staple diet. Most people extended their basic recommended list by adding dried beans, rice, dried fruit, tea, vinegar, pickles, ginger, mustard, and saleratus (baking soda). While pioneer women were used to baking bread at home, it took some experimenting and practice to bake bread in a dutch oven or reflector oven under prairie conditions with a buffalo chip fire, blowing ashes, dust and insects. Corn meal, and pilot bread or ships biscuits were also welcome additions.

While the science of dietetics was not completely understood, there were many suggestions to help ward off scurvy, dysentery and other ailments obviously directly related to an inadequate or unbalanced diet. Some pioneers brought a few chickens along in cages tied to the side of the wagon. Many drove milk cows along, especially those with small children. Milk was a health giving supplement to a family diet made up of mainly meat and bread.

The standard date for departure from any of the jumping-off places was April 15, give or take a week or two, with expected arrival in Oregon or California by hopefully September 1, but not later than October 1. An ideal crossing was 120 days, April 15 to August 15, a daily average for the 2000 mile long trail of 15 miles per day. A more realistic crossing took about two weeks longer. On a good day more they 15 miles could be covered, on a bad day, much less.

In many wide open places, trains broke up into two or more columns, spreading out to relieve the pressure on the road, in many places, once in line, stay in line. There were frequently quarrels between cattle and horse teams. Cattle were largely in the majority, and some of the drivers

seemed to take delight in holding up the faster traveling horse teams in narrow spots.

The day usually started about 6 am and lasted until around 5 pm with a one hour rest at noon. This "nooning" was essential because it gave both man and beast a much needed rest. The oxen were not un-yoked, but allowed to graze.

The first order of business at the end of the day was forming a corral by pulling the wagons into a circle. It was normally circular or oblong shape with the tongue of one wagon chained to the rear of the neighbor's to form a fence. Originally designed as a defense against Indian attacks, which were rare, or desperadoes and wild animals, it became an institution, as much for companionship as anything else. An opening or two was left for passage of livestock which could be closed with the tongue of a wagon.

The evening campfire was important beyond debate. It provided comforting warmth, a place to dry wet clothes, and cook a hot supper. While the Platte River bottoms are choked with trees today, 150 years ago, frequent prairie fires kept the trees from maturing. How did the emigrants keep warm and fry their bacon and bake their bread? By cutting green willows when available, burning drift wood when found, breaking up the occasional abandoned wagon box, twisting dry grass into tight twists, or when the buffalo country was reached, using dry "buffalo chips", sometimes called prairie coal.

Water was important, of course, but was not a real problem from Missouri to South Pass. Most people took their supply directly from the Platte, which one witty traveler described as too thick to drink and too thin to plow. If springs were found, this was better water. The fastidious often tried to filter out some of the sand and other particles found in the river water. Some boiled their water, not so much to insure its safety, but to kill the wiggle-tails. Drinking untreated water was doubtless a factor in the high mortality rate.

Sleeping arrangements were elementary. Women and children might sleep on storage boxes in the wagon, but most likely bed was a blanket, a piece of canvas, and an India rubber cloth or buffalo robe on the ground. Tents were luxuries, and blew away in the wind, or often simply discarded. No sleeping pills were needed by the emigrant...fatigue and exhaustion made the ground seem soft.

The Oregon migrations were a family affair, often running at least 50 percent women and children. There were courtings and marriages among the young and unmarried members of the trains.

There was a high incidence of childbirth on the trail, and often those who kept diaries made no mention of an impending birth until a short entry announced the arrival of a new member of the family. Tragedy often came with the arrival of an infant, with death in childbirth not uncommon. Infant mortality was also high. Poor nutrition, lack of medical care and poor sanitation caused many of these deaths. A contributing factor was the necessity to keep moving westward.

Religion played a large role in the westward migrations, for a majority of these pilgrims were devout church goers. While it was not practical to lay over on Sunday, some sort of sabbath



observance was usually held. If the train rested on the Sabbath, the women washed clothes or did extra cooking and the men repaired wagons, harnesses, etc.

Given the extremes which tested the emigrants to the limit of their endurance and fortitude, the evidence of crime among the travelers was low. Under the circumstances, the vast majority of folks behaved admirably. There were no civil laws, no marshals, sheriffs, or courts of law to protect those who crossed the plains. The military offered some protection near the forts, but that was limited. The only effective law was the inward sense of morality and the outward law-abiding sense that was normal for most pioneers.

While some people seemed to thrive on the excitement and adventure of the journey across the plains, for many it was an ordeal. After surviving untold hardships, there arose the threat of disease and death. There are, of course, no valid mortality rates available. Estimates are as large as 30,000 deaths, but a more conservative estimate is 20,000 for the entire 2000 miles of the California trail, or an average of ten graves per mile. Assuming the grand total of 350,000 people immigrating is correct, that averages one death for every seventeen persons who started.

Deaths occurred from poor sanitation practices in cooking and food storage, and bad water, and poor living conditions. Some people suffering from "consumption" or tuberculosis, made or tried to make the trip because it was believed that outdoor exercise would overcome the disease. What better exercise than walking across the prairie! Pneumonia, whooping cough, measles, small pox and various other miscellaneous sicknesses caused many deaths. Cholera was especially a problem, and the greatest killer of all.

Accidents associated with wagon travel took their toll also. Drownings, being run over by the wagon, accidental shootings, injuries from handling animals caused injuries and maiming as well as deaths. Fatigue caused carelessness and carelessness led to accidents.

The weather was among the hardships along the Platte and one which simply had to be endured. April and May could be cold and wet, and since the emigrants traveled with a meager supply of clothes and bedding, many were uncomfortable. Later heat and dust became the enemy. When it rained low places became bogs for wagons to mire down in, and rivers that had to be crossed became raging torrents.

After surviving the great prairies and Rocky Mountains, making their way along the Sweetwater and Snake Rivers, the Blue Mountains still had to be crossed. Many found the road through the Blues more difficult than crossing the Rockies. Travelers then journeyed across eastern Oregon to the Columbia. For some historians, the Oregon Trail ended at The Dalles, but many others believe it's true end is at Oregon City.

After reaching The Dalles, the wagon floated down the Columbia on rafts until 1846 when The Barlow road was built around Mount Hood, giving travelers an alternative to river travel.

Finally, the Valley of the Willamette. Here was the land office where you could file your land claim, where hopes and dreams either blossomed and bore fruit or died. Those who had endured, came to this valley to seize the land, settle it, come to terms with it and to call it home.

# OREGON TRAIL NORTHWEST LANDMARKS

The following contain short descriptions of the main landmarks and stopping points that were significant in the Northwest Region of the Oregon Trail. This Teacher's Guide is primarily devoted to the geographical areas and peoples found around and about these important locations.

## SODA SPRINGS

One of the most pleasant places on the Oregon Trail was this area in Idaho where springs of carbonated water bubbled from the ground. With a little sugar added to it, the water tasted very good to weary travelers. Today, all the springs are gone except Hooper Spring on the outskirts of Soda Springs, Idaho. A little pavilion has been built over it where visitors can still see the tiny bubbles rising to the surface. The other springs are dry or under the town reservoir.

## FORT HALL

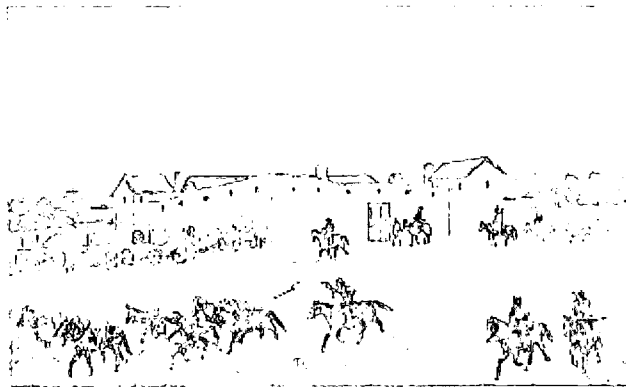

The trail north from the Bear River to the Portneuf River, which would take travelers to Fort Hall, was hard, but by now the road-hardened travelers handled it routinely. Nine or ten days travel brought them to Fort Hall, that remarkable outpost of Yankee entrepreneurship in the wilderness.

Fort Hall became a Hudson's Bay Company trading post shortly after its construction. Travelers rested here and got new supplies when they were available. The fort finally fell into disuse when a new cutoff trail was made south of it. The original site of Fort Hall is on private property today, but a replica has been built in the city of Pocatello where visitors may see how the original fort looked.

The fort was abandoned in 1855, but emigrants continued to camp in the abandoned buildings and graze stock in the pastures until 1863. That year extraordinary floods swept away even the remains; but by then most wagons were using the Hudspeth Cutoff (located to the south) and never got this far.

From Fort Hall the Oregon Trail swung slightly south of west again; another mountain range to get around. Now they followed the Snake River, and would for over 300 miles. And what a river! Some emigrants had never seen one like it. They had driven wagons across the Platte when it was a mile wide, but this was a torrent, battering the jagged walls of its lava canyon.

### **AMERICAN FALLS**

The pioneers continued to follow the Snake River after leaving Fort Hall. The road they followed was rough and difficult. It was described as being "a very rocky road hard on wagons...the river had precipitous banks in places 200 feet of rock perpendicular." They passed American Falls, really a rapid, but the noisiest falls some of them had ever seen, and repeated the story that it was named for some American trappers who were swept over and drowned.

Most of the Oregon Trail route through Idaho runs along the Snake River. At American Falls the river dropped fifty feet in Oregon Trail days. Now, because of locks and dams, most of the falls are dry, except in the spring.

### **THREE ISLAND CROSSING**

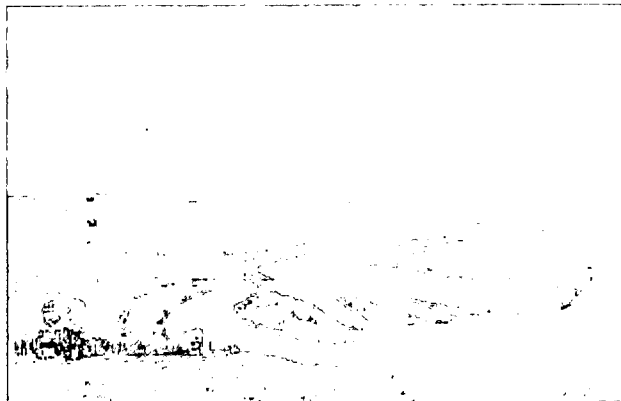

When the Snake River was wild and untamed, it was dangerous to cross. The water was deep, fast, and usually extremely cold. However, crossing the river saved many miles of travel to Fort Boise. Wagon trains made the crossing near present day Glens Ferry where there were three small islands situated like stepping stones across the river. These three islands split the current into channels and made crossing easier. Where the channel was most narrow between the bank and the first island, they pushed in their cattle and wagons, crossed, then went to the head of the next island, repeated this process one more time, and if no other mishaps occurred while negotiating the river, the crossing was completed.

Indians sometimes harassed the wagon trains at Three Island Crossing, and a party which got only half its wagons across and had to camp on both sides of the river would have difficulty guarding both camps adequately that night. If the water was too high, the south alternate trail was used, but it was longer and more difficult.

Today, visitors can stop at a state park and look across the river where the old wagon ruts come down to the water's edge.

## **FORT BOISE**

Because some emigrants failed to ford the Snake River back at Three Island Crossing, they stayed on the south branch through rough land south of the river. The other half used different routes on the north side. The main north trail first headed toward Teapot Dome, a hill resembling a turtle that once had steam from hot springs rising around it. Eight miles from this location, they could see the valley of the Boise River, a delight to eyes which had endured the blasted, volcanic landscape along the Snake River for 350 miles. Heavily wooded, it promised shade and firewood. The city of Boise, capital of Idaho, sprouted there. Volunteers established Fort Boise, an Army post, in 1863 in Boise. Its occupants protected Oregon Trail emigrants and helped suppress Bannock Indians in 1878.

Forty-five miles to the west, the Hudson Bay Company had built an earlier Fort Boise as a trading post. A flood severely damaged it 1834. Fort Boise was another Hudson's Bay Company post where overlanders could rest and get supplies. Nothing remains of it today, but the location is marked with an interesting monument in the shape of a lion's head. A replica of Old Fort Boise has been constructed in the nearby town of Parma, Idaho.

## **FAREWELL BEND**

The Oregon Trail followed the Snake River for only a few miles after entering Oregon. At Farewell Bend, overlanders said goodbye to the Snake and turned northwest toward the Columbia River. Pioneers called this departure from the Snake River "Farewell Bend" and that is still its name today. Even though they were getting closer to their destination, there were still many hardships ahead of them.

There was something contradictory in the mood that struck the emigrants along this stretch of the trail. There was excitement and exhilaration in being so close to the ending of such a monumental effort, but the great Blue Mountains lay ahead and the thought of crossing these mountains worried the travelers a great deal. Though the snow that blanketed these mountains was indeed beautiful, it also posed a serious threat to the weary travelers.

## Flagstaff Hill



Flagstaff Hill was another hard pull for the wagon trains. Almost everyone was getting truly exhausted by this time. Most of the emigrants had left Missouri in late May, and reached Flagstaff Hill around the middle or end of September. Many months had already passed, and there were still more to go. Many animals had already died along the way, and in places, dead animals literally littered the trails. A great number of people had died too, and often, because of the constant pressure of needing to continually keep moving west, these unfortunates had been hastily buried along the trail. When the overlanders reached the summit of Flagstaff Hill, they saw the beautiful Baker Valley spreading out below them--full of grass and water, but they also saw the awesome snow-covered Blue Mountains rising up in the distance. Despite the serenity of the Baker Valley below them, the travelers knew that they still had many hard miles ahead of them.

## WHITMAN MISSION

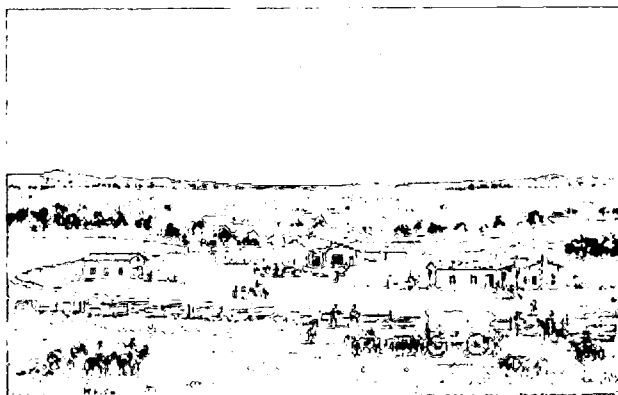

In 1836, Dr. Marcus and Narcissa Whitman, the Reverend Henry and Eliza Spalding, and William H. Gray crossed the North American continent from New York state to a remote and largely unknown land called Oregon. They journeyed to Oregon in order to establish missions

and to teach the Indians of the area about Christianity. Dr. Whitman established his mission among the Cayuse Indians at Waiilatpu, and the Reverend Spalding began his work among the Nez Perce near Lewiston, Idaho. The trail the Whitmans followed across the continent, in part, had been established years earlier by Indians and fur traders. The primary route later became known as the Oregon Trail.

Narcissa Whitman and Eliza Spalding were the first white women to cross the entire continent, and the Whitmans' baby, Alice Clarissa, was the first child born of United States citizens in the Pacific Northwest. These two events inspired many families to follow, for these acts proved that families and homes could be successfully established in Oregon, a land not yet belonging to the United States.

In the fall of 1842 two important events occurred:

1. The first large group of emigrants to travel to the Oregon country stopped at Whitman Mission for rest and supplies. (Wagons had been taken as far as Fort Hall in Idaho, then, belongings were repacked on horses and the travelers continued to the Willamette Valley on horse and foot.)
2. The American Board of Foreign Missions received reports of dissension among the missionaries. This dissension, as well as lack of money caused the American Board to order the Waiilatpu and Lapwai Missions closed. In a desperate attempt to save the missions from closure, Dr. Whitman rode from Whitman Mission all the way back to New York to plead that the missions remain open and active. Dr. Whitman was successful, and the missions remained open.

On his return to Oregon, Dr. Whitman successfully helped lead the first wagon train of emigrants to the Columbia River. This event provided the final thrust for the western expansion of the United States. The Whitman Mission, throughout the rest of its existence, was a haven for the overland traveler. Those who traveled via the mission could get medical care, rest and supplies.

The Whitmans worked among the Cayuse and Walla Walla Indians for 11 years. The Whitmans attempted to teach the Indians principles of Christianity and the rudiments of agriculture, and Dr. Whitman also provided medical services. Dr. Whitman's success as a missionary however, was limited. Even though many of the Indians liked and respected him, some threatened the missionaries and destroyed mission property. Despite setbacks and occasional hostility, the Whitmans refused to abandon the mission. Their best efforts failed to prevent distrust and unrest among the Indians, and, on November 29, 1847, the mission effort ended in an outbreak of violence.

Several causes led to the rising Indian resentment. Increasing numbers of emigrants entering their country and stories of settlers taking Indian land elsewhere convinced the Cayuse that their way of life was in danger. Their fears grew as a measles epidemic, brought in 1847 by the emigrants, spread rapidly



among the Indians. The Cayuse had no natural resistance to the new disease, and within a short time over half the tribe had contracted the measles and had died. When Whitman's medicine seemed to help the white children but not their own, many Cayuse believed that they were being poisoned to make way for more whites.

In a tragic and bloody attack, born of deep misunderstandings and grievances, a small group of Cayuse attacked the mission and killed Marcus Whitman, his wife Narcissa, and 11 others. The massacre ended American Board missionary work among the Oregon Indians. It also led to a war against the Cayuse, waged by settlers from the Willamette and lower Columbia Valleys.

In 1848, Joe Meek carried news of the tragedy, along with petitions from the settlers, to Washington, D.C. The massacre spurred Congress into creating the Oregon Territory in August of that year, thus forming the first territorial government west of the Rockies.

## **MOST FREQUENTLY ASKED QUESTIONS ABOUT THE WHITMAN MISSION**

1. Was the mission built on the hill?

No. The mission grounds lie to the south of the present day visitor center. The concrete structure on the hill is a memorial shaft to the Whitmans and their co-workers. It was dedicated in 1897, during a 50th anniversary celebration of the Whitmans' deaths. (The Great Grave was also dedicated at this time.)

2. Why did Whitman choose this location for his mission?

The Whitmans and the Spaldings intended to settle among the Cayuse and Nez Perce. Together they decided to build two missions instead of one mission. It was then decided that Spalding would settle further east and the best site for Whitman Mission was in the vicinity of Walla Walla. Five good reasons for choosing Waiilatpoo as the site are:

- a) The Cayuse Indians lived in this area. The Walla Walla and Umatilla Indians also resided in the region.
- b) The site was near the location of the Hudson's Bay Company's Fort Walla Walla. Fort Walla Walla was located directly on the main communication line which linked Vancouver and Montreal.
- c) The chosen site marked the end of the long trail that wound through the Blue Mountains. Also, the Columbia River was nearby, and this river was the main artery of trade and travel in Old Oregon.
- d) The two rivers provided ample water and good soil for farming. e) The Cayuse offered this land to them.

3. Were the Cayuse the only Indians with whom the Whitmans worked?

No. The Whitmans also worked with the Walla Walla, Umatilla, and to a lesser extent, the Nez Perce Indians.

4. Where were the Whitmans originally from?

Marcus Whitman was born September 4, 1802 in Rushville, New York. Narcissa Prentiss Whitman was born March 14, 1808 in Prattsburg, New York.

5. What religion were the Whitmans?

Presbyterian. Marcus was made a Presbyterian elder of the Wheeler Church in 1834.

6. Where did Whitmans' child drown? What was her name and age at the time of her death, and where was she buried?

Alice Clarissa, born March 14, 1837 (on the evening of Narcissa's twenty-ninth birthday) was the first white girl born of American parents west of the Rockies. She died Sunday, June 23, 1839. She was two years, three months and nine days old. At approximately 2:30 in the afternoon, Alice went down to the river to get some water in two cups. Soon after, two (2) cups were observed floating in the river. After some time searching along the river, an old Indian found her body caught on a tree root which extended into the river. The exact location of her grave is not known today. It is believed to be in the vicinity of the current Great Grave.

7. Did the killings take place on the hill?

No. Marcus was the first one killed, in the Mission House kitchen, November 29, 1847. Others died at various spots at and near the mission, one died escaping, one died traveling towards the mission.

8. Were all the people at the Mission killed?

No. Out of seventy-five, thirteen were killed, seven escaped (including Hall, who disappeared), three half-breed boys were released, fifty were held captive. Of the fifty captives, two children and one adult died of measles. The remaining forty-seven were ransomed on December 29, 1847 by Peter Skene Ogden of the Hudson Bay Company.

9. How old were the Whitmans when they were killed?

Marcus Whitman was forty-five years old and Narcissa was thirty-nine years old.

10. What happened to the Mission buildings?

After the killings, the Indians destroyed everything they could. When the Oregon



Volunteers arrived they partially rebuilt the main Mission House, and changed the name to Fort Waters. After they left, the Indians in the area once again destroyed all structures. Luckily for archaeologists, the fires caused the Mission House roof to fall on the foundations, preserving them.

11. Where was Fort Walla Walla?

There have been two Fort Walla Wallas in the Walla Walla Valley:

- a) In 1818, the Northwest Fur Company built a fort near the confluence of the Walla Walla River and the Columbia. This was first known as Fort Nez Perce, but in later years its name was changed to Fort Walla Walla. Within the thirty-seven years of its existence, there were three forts built in this area, each one replacing the previous fort. In 1821, the Hudson's Bay Company took charge and operated the fort until the Indian troubles began in 1855. This fort is the one that is mentioned in the Whitman story.
- b) The second Fort Walla Walla was built in 1856 in the city of Walla Walla. Later it was moved to a location which is now behind the Veterans Hospital. It was strictly a military fort and did not have any bearing on the Whitman story. It was abandoned about 1910. This is the site of the present day Fort Walla Walla park, cemetery and museum complex, as well as the Veterans Hospital and grounds.

## THE DALLES

The land trail stopped here until Samuel Barlow built a road around Mt. Hood in 1845. Getting from Whitman Mission to the Columbia River was not a problem for the travelers. Emigrants who had visited Whitman Mission often went down the Walla Walla River to the Columbia River, while other travelers who took the southern route through Pendleton and Echo chose the Umatilla. Once they reached the Columbia River, a major decision had to be made--What now? Some travelers built boats or rafts, while others hired Indian boatmen with their great canoes to get them down the river. The weary travelers were facing the challenge of the Columbia, an enormous river carrying the volume of all the rivers they had already crossed combined. This magnificent river was full of rapids, huge rocks, high cliff walls, all posing tremendous dangers to the travelers. Many family members and friends lost their lives at this point, having already covered the many arduous miles now behind them.

The more cautious of the travelers carefully worked their wagons down the banks of the Columbia, but then came the Dalles, a place in the river where two great rocks restricted and channeled the flow of the entire river between them. (The Dalles translates literally to "the trough".) There was absolutely no way for the wagons to continue on down the riverbank, for it was about to cut through the Cascade Range, creating the Columbian River Gorge. At the Dalles some emigrants carried their belongings around the falls, then traded their oxen to Indians for boat fare downstream. If all went well, it could be as little as two days on the river.

## BARLOW ROAD

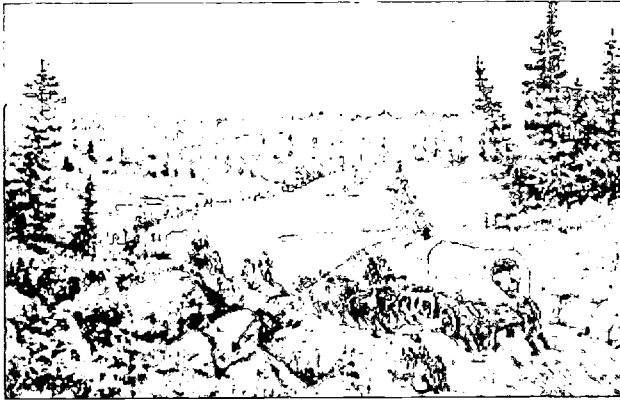

After 1845 there was an alternative to the water route on the river, but it was not an easy one. In 1845, Samuel K. Barlow, from Illinois, came upon the scene at the Dalles. He became very disgruntled at the high tolls being charged to get the emigrants down the Columbia, and was also very concerned about the extreme hazards and dangers along this river section of the journey. Samuel created a wagon road over the Cascades around the south side of Mt. Hood.

### QUESTIONS AND ANSWERS ABOUT THE BARLOW ROAD

1. Q: What is the Barlow Road?

A: The Barlow Road is the last overland segment of the Oregon Trail.

2. Q: Why is the Barlow Road important?

A: The Oregon Trail was named a National Historic Trail by Congress in 1978. The Historic Trail designation was meant to protect the trail remnants and artifacts for public enjoyment. Very little of the original Oregon Trail is visible today (about 20%). Of this 20%, approximately 10% is on National Forest land. The Barlow Road is a piece administered in part by the Forest Service. The Barlow Road was placed on the National Register of Historic Places on April 13, 1992 as a Historic District.

3. Q: Why is the Barlow Road unique compared to other locations along the Oregon Trail?

A: The Barlow Trail is the first place on the 2,100 mile Oregon Trail where tolls were charged.

4. Q: How much were the tolls?

A: When the road opened in 1846, tolls were \$5.00 per wagon and 10 cents for every head of livestock. By 1863, tolls had changed to \$2.50 per wagon and team, 75 cents for horse and rider, and 10 cents for other livestock.

5. Q: Was that considered a lot of money?

A: \$5.00 was about one week's wages. Consider the alternative -- floating down the Columbia River in boats or rafts cost nearly \$50.00!!!

6. Q: Where was the Barlow Road located?

A: Many say it started in The Dalles, but in 1845 when Sam Barlow scouted the new road, a route already existed from The Dalles to Tygh Valley. By 1850, many emigrants by-passed The Dalles by going straight from the John Day River to Tygh Valley--crossing the Deschutes River at Shearers Bridge. Tygh Valley could be considered the beginning of the Barlow Road.

The National Park Service considers the start of the road to be the first tollgate site on Gate Creek. Whatever starting point you choose, the ending was always Oregon City--the "End of the Oregon Trail."

7. Q: When was the Barlow Road used?

A: It operated under many owners as a toll road from 1846 to 1915. It was free until 1919 when the estate of the final owner deeded the road to the State of Oregon. Much of the road on the Forest is still in use today for recreation activities.

8. Q: How old was Samuel Barlow when he started the Barlow Road?

A: Barlow was 53 years old in 1845 when he helped lead the first wagon train of emigrants around the south side of Mount Hood.

9. Q: Is the Barlow Road intact on the Mount Hood National Forest?

A: The Mount Hood National Forest maintains 40 miles of Barlow Road corridor. About 30 miles remain "intact," but not always like you would expect it. The Barlow Road underwent an evolution of travel modes--from oxen-pulled wagon to Model A Fords. Motorized travel meant mechanized re-routing and maintenance. The new motorized routes (including Mount Hood Loop Highway of 1924) left many isolated pieces of "pristine wagon ruts." These rut traces are visible today. In the Zigzag Valley, much of the original route is beneath U.S. Highway 26.

10. Q: What pioneer graves can be seen along the road?

A: In addition to "Pioneer Woman's Grave," several others exist at Summit Meadow. These are on private land across the street from where the Summit House stood.

11. Q: Are the ruts along the road just two parallel tracks? A: No. The ruts you will see are actually a swale--a five to six foot wide trench worn out by the wagon and the

stock that pulled them. Near "Pioneer Woman's Grave," they get four to five feet deep.

12. Q: Where are the best ruts to see located? A: Many fine traces exist near Pioneer Woman's Grave, Barlow Pass and Devil's Half Acre. They are within 2-- feet of paved parking at the first two sites. The hiking trail from Barlow Pass to Pioneer Woman's Grave has some of the best to be seen and they are marked with rustic "Original Wagon Route" signs. It is about a one mile hike--you can go up or down. Other ruts exist on Laurel Hill--these remain for the true "rut nuts" to search out and discover without formal maps.

13. Q: Are rope burns still visible on trees on Laurel Hill from wagon lowering?

A: No. A stump with rope burn was near the top of chute number two, but the marks have disintegrated through time.

### **Fort Vancouver**

Those who traveled to Oregon City by water from The Dalles came first to Fort Vancouver, a Hudson's Bay Company fort and trading post. Fort Vancouver was the headquarters for the Hudson's Bay Company's Columbia Department, embracing present-day British Columbia, Washington, Oregon, and Idaho. The trading post also represented Britain's business and governmental interests in competition with the United States.

The fort's warehouses stocked supplies for the fur brigades, the Indian and settler trade, and for the 20 to 30 other Company posts in the Department. Most Indians were shrewd traders, so trade goods were carefully chosen. Almost all of the trade items were imported from or through Britain, so there was a two-year lapse between ordering and receiving. The fort's shops bustled with activity, manufacturing as many items as possible. The fort echoed to the sounds of carpenters hammering and sawing, of blacksmiths making tools and repairing old ones, and of coopers making barrels. Carts rumbled to and from piled high with supplies and with firewood for the bakery's large brick ovens. Indians arrived continually to trade, passing farmers and herders tending crops and livestock. Company clerks bent over their account books figuring out how much who owed whom. Frequent visitors were welcomed and eagerly quizzed for news and gossip of the outside.

### **Oregon City**

Whether the route taken was by water or by land, the final destination for most overlanders was Oregon City on the Willamette River. They didn't all come to Oregon City and pile up on one another, rather, Oregon City became more of a symbolic site. Men left their families at Oregon City while they searched for a place to call home. Oregon City had the only judicial court and land office in the Western United States. The emigrants arrived by the dozens. Some arrived needing food, shelter, and clothing while others made it across in grand style with two or three wagons and plenty of livestock. By 1845, Oregon City had grown into a town of nearly one thousand people. The town had a Methodist Church, a Catholic chapel, two grist mills with a

sawmill at each, four stores, two taverns, a hatter, a tanner, a physician, three lawyers, a printing office and newspaper, a lath machine and a good brickyard. There were plenty of carpenters and masons employed.

Oregon City is also the town in which two men, Amos Lovejoy and Francis Pettygrove flipped a coin to decide what the new city north of them would be called. This city was where the Willamette flowed into the Columbia river. Each man wanted to name the city after his hometown back East. Amos wanted the town to be called Boston (Massachusetts) while Francis wanted it to be called Portland (Maine). Pettygrove was the winner of the coin toss, hence, the city of Portland was established becoming a suburb of Oregon City.

One mystery still remains and that is the origin of the name "Oregon" which is what Oregon City is named after. The British, French, and Spanish all had interests in this northwest country and the name Oregon was possibly derived from a mixture or blend from all three of these nations' languages. The earliest written account of the name Oregon comes from the English Army officer Major Roberts in 1765. He assumes the Columbia River to be the Ouragon or Ourigan River. So whether the name is derived from the Spanish words oregano, oreja, and orejon or from the French word Aragon the fact remains that we now refer to it as Oregon.

# OREGON TRAIL TEACHER'S GUIDE

## SECTION TWO - THE FIRST PEOPLE IN OREGON

### PREHISTORY OF OREGON

More than twelve thousand years ago, the land that today is known as Oregon was covered with forest, mountains, and high desert. Scientists have named this time in history the Paleo-Indian Period. Paleo (PAY-lee-oe) means "ancient" or "long-ago." People who lived in ancient Oregon were Indians. They were the first Oregonians. It is their belief that the Creator created them on the North American continent and that they have always lived here.

We know little about these Indians because they did not leave any written record of their lives. Scientists, however, have learned about these Indians by studying the drawings and objects that they used. These objects are called artifacts. They are the signs that scientists use to guess what the people's lives were like.

One of the most interesting clues about the early people of Oregon are rock drawings. Petroglyphs are some of the earliest known communication of people in the western half of the world. No one is sure exactly what the figures meant to these early people. Many of them seem to show things in their daily lives. Some show people and animals. Others might show the power of nature, such as the rain or the sun. Still others are unknown.

Some other artifacts scientists have found are stone points, which were used for spears. From these artifacts, scientists have learned that the ancient Indians were hunters. They used spears to hunt large animals that are now extinct, such as American lions, ancient bears, and giant sloths. The Indians threw spears at these animals, and used a spear-thrower that helped them throw the spears harder and farther.

Another thing that scientists have learned from artifacts is that these Indians probably only lived in one place for a short time. Then they moved on, searching for food.\*\*

*\*\*This same text can also be found under the Social Studies section of this guide and has been set up as a question and answer activity sheet for students.*

# INDIAN CHILDREN

Indian parents do not praise or reward their children for doing what is proper or right; they are expected to behave well, for this is natural and normal. Thus, a good Indian child is simply behaving as a child of his people should behave. On the other hand, a bad child is censured and the child who makes mistakes is shamed which, in an Indian community, is a grave punishment. As a result of the way they are raised, very few Indians will try to do something at which they are good; it takes a lot of courage.

A profound respect for the interests of others begins to show even in a very young Indian child. Children never interrupt parents. A little girl might leave the play group for a while and lean against an adult relative or sit in a lap. But only in grave emergency would she try to attract the attention of an adult. Subconsciously, children learn not to interfere or bother older people who are busy.

Indians rarely discipline their children in a fashion comparable to white parents. At first, a child that has misbehaved is ignored and gently set aside until later, when they would be addressed directly in a firm manner. Parents would often confide in a "whip man" regarding a child's bad behavior and he would deliver a stern talk to the child rather than having the parent perform this task. Often, receiving a stern talk from a whip man would have a profound and lasting effect on a misbehaving child. Indian parents are by no means busy all the time, and when they are unoccupied they like nothing better than to cuddle, play with and talk to little children. When an Indian gives his attention to a child, he gives all.

Educating the young in the traditions of their culture was an important and honored task for grandparents, and their responsibility as instructors covered a wide range of subject areas. For instance, grandmothers often made traditional articles of dress for their grandchildren and both grandparents were often responsible for moral instruction as well. Grandmothers would teach their granddaughters how to cure leather hides, clothing design, construction and ornamentation. Grandmothers would also teach granddaughters techniques regarding food gathering and preparation. Grandfathers would teach the boys about design, construction, and use of weapons and tools. Grandfathers also instructed boys in the care, handling, and training of horses. A very strong tie between young and old was established early and was maintained throughout one's entire life.

Babies were kept in cradle boards during their first year after which time they were taken out of these cradleboards and were taught to walk. Children learned at a very early age to take pride in their ceremonial dress and often looked forward to special occasions that would provide them an opportunity to dress up in ceremonial fashion. At these times, beautifully decorated, colorful attire was worn by all. Feathered headwear was made for children, as well as traditional leggings, wing dresses, decorative feathers, intricately beaded and ornamented vests, dresses, shirts and shawls. Children often wore the same styles of clothing as worn by their parents.

Gifts of new or special articles of clothing were given to children at birthdays as well as for recognition of honors or awards earned, and for graduation from school. These items were highly



treasured and kept during most of a person's life. These gifts were a symbol of respect of others and children held these gifts in high regard.

There were certain ceremonies or celebrations held specifically for children that were the beginning of passage into adulthood. For example, a feast was held to celebrate a girl's first gathering of roots or a boy's first kill of wild game. These children were being honored for making initial accomplishments that would eventually lead them into more of the role of an adult. Once these important tasks had been successfully completed by young girls or boys and a ceremony had been given in their honor, they finally had made the passage from childhood into adulthood.

## **INDIAN TRIBES OF NORTHEASTERN OREGON**

### **GENERAL INFORMATION**

The Plateau Indians of the Oregon Territory lived in the area between the Cascade Mountains and the Rocky Mountains. Much of this area is high flat land, but there are also mountains, canyons, and many rivers and valleys. Part of this area is now the eastern part of the state of Washington, including the place that is now the city of Walla Walla. Some of the tribal names were Snake, Cayuse, Umatilla, Yakima, Spokane, Palouse, and Walla Walla; all familiar place names in this area today. The groups of the Plateau moved from place to place to gather edible vegetables and fruits, including camas, kouse and bitter-roots, serviceberry, chokecherry, huckleberry, and wild strawberries. The gathering of these plants is still a traditional way of life among many of the people today.

They made woven bags out of Indian hemp and the designs were created out of grasses, such as rye grass, bear grass or hemp and later, corn husks, in different sizes and shapes for carrying their harvest and personal belongings.

Their homes were movable tepees made of poles covered with mats made of tule (pronounced too-lee) grass, a tall, tough reed that grows marshy areas. In winter they made more permanent homes. They dug a pit a few feet into the ground and over it constructed a framework of poles which they covered with the tule mats. Then earth was piled up around and partly over the structure to provide insulation. Later, canvas was used instead of tule mats.

In addition to hunting and gathering, these Indians were fishermen, with salmon making up a major part of their food supply. When horses came to the area, the world of the Plateau people expanded, allowing them to trade for buffalo with the tribes on the plains east of the Rocky Mountains and groups of hunters rode far to hunt buffalo, deer, and elk.

### **NEZ PERCE INDIANS**

The Nez Perce lived in the valleys of the Clearwater and Snake Rivers and their tributaries. Originally dwelling in fishing villages along rivers, they built large, multi-family lodges of



timbers topped with grass, tule, and cattail mats. Salmon was the mainstay of their diet. The Nez Perce hunted in the woodlands, and dug the bulbs of the camas lily on the high plateaus. Often, several villages formed a loose confederation, or band, so that resources could be pooled for long hunting trips or for war.

Spanish invaders introduced horses into the New World in the 16th century, but it was a long time before Indians had them in large numbers. The Nez Perce acquired horses perhaps as early as the end of the 17th century. These Indians developed their horse herds with great care. They selectively bred their horses by gelding or trading away inferior specimens and importing superior breeding stock. This produced well built, strong horses that were highly prized. The tribe especially favored the colorful, spotted Appaloosas, an ancient breed which the Nez Perce diligently perfected.

They quickly adapted to the new mobility horses provided. Bands of Nez Perce crossed the Rocky Mountains and met, traded with, and fought Indians on the high, northern plains. They hunted buffalo and lived in skin-covered tepees. They adopted the eagle-feather headdress, horse accessories, games and customs from their new acquaintances. Even the many Nez Perce who remained in the traditional homelands could not help but be affected.

By the time of the American Revolution, the Nez Perce had begun to feel the impact of a new people from another land. Their first meeting with the whites took place in September, 1805 when Lewis and Clark led a small group across the Bitterroots into Nez Perce Country. The Nez Perce received them graciously, gave them supplies, and told them about the river to the Pacific.

Soon, fur trappers and traders, both British and American, entered the region. In the 1840's, settlers began to make their way westward along the Oregon Trail, and in 1846 the Nez Perce found themselves surrounded by United States boundaries when the United States and Britain divided the Oregon Country along the 49th parallel.

Washington Territory, which included all of Idaho and part of Montana, was formed in 1853, and its governor, Isaac Stevens, wanted to divide up Indian lands in that territory into reservations. He called the leaders of the Nez Perce together in Walla Walla in 1855. An agreement was reached that reserved most of the Indian traditional homeland as their exclusive domain.

The discovery of gold on the Nez Perce Reservation in 1860 raised calls from the whites who wanted a smaller reservation that would exclude the gold fields. So, in 1863, a new reservation, containing only one-tenth of the land originally set aside, was proposed to the tribe. Lawyer, a pro-American, Christian leader, and his followers accepted the plan and signed the treaty. Other Nez Perce leaders rejected it, giving rise to the "treaty" and "non-treaty" designations of the respective factions.

The Americans, claiming that Lawyer represented the entire tribe, asserted that the agreement was binding on all, but to the Nez Perce, this was not true, or even possible. Lawyer could only sign away his land, no one else's. After President Andrew Johnson signed the treaty in 1867, the United States government launched a campaign to move all the Nez Perce onto the reservation.

The Nez Perce leaders who had not signed the treaty and who lived off the new reservation ignored the orders. Foremost among them was Old Joseph, who led a band that lived in Oregon's Wallowa Valley. Young Joseph, who succeeded his father, hoped that a peaceful solution could be found, for he did not wish to go to war or to leave his home. In May 1877, the non-treaty Nez Perce were told that the U.S. Army would forcibly move them onto the reservation. So in early June, Joseph and his people crossed the Snake River into Idaho and camped near Tolo Lake while preparing to move onto the reservation by the June 14 deadline.

On the morning of June 13, three young men, angered at what was happening and seeking revenge for the murder by a white man of one of their fathers, rode out into the dawn. By midday of June 14 they had killed four settlers. Joined by 17 others, the group killed 14 or 15 whites in the next two days. Knowing that General Oliver O. Howard would retaliate, the Indians headed for White Bird Canyon. There on June 17, 1877, a small body of warriors imposed a crushing defeat on a superior force of soldiers, killing 34 and losing none. Skirmishes at Cottonwood in early July and a battle on the Clearwater on July 11 and 12 proved inconclusive. At Weippe the non-treaties decided to cross Lolo Pass into Montana in the hope that they could escape the war and live there in peace. The bands, totaling about 750 men, women, and children, hoped also that their buffalo-hunting friends, the Crows, would help them.

In all their hopes, they were disappointed. More and more soldiers came after them, eventually totaling more than 2,000. Instead of helping, the Crows harassed them. At Big Hole, August 9 and 10, they lost between 60 and 90 lives in a surprise attack by U.S. troops and volunteers. Still they managed to elude the United States Army until October when they were forced to surrender just 42 miles short of the Canadian boundary and refuge.

The last years of the 19th century and the early years of the 20th century were difficult ones for the Nez Perce. White values and culture were forced upon them by the missionaries and government officials. The General Allotment Act of 1887 aimed at giving individual Indians title to anywhere between 40 and 160 acres (the Nez Perce average was 90 acres) in the belief that ownership of land would more swiftly assimilate them into the mainstream of American life. The unallotted land was sold to the general public. Shortly, more than 70 percent of the reservation lands was in white ownership.

In 1948 the Nez Perce Tribe of Idaho became a self-governing body under an approved constitution and bylaws. In 1961, a revised constitution and bylaws were adopted. The Nez Perce People have not lost sight of their proud past; their history is not over.

## Indian Tribes of the Northwest



## PARTIAL BIBLIOGRAPHY

Slickpoo, Allen P. Noon nee-me-poo (We, the Nez Perces): Culture and history of the Nez Perces. Allen P. Slickpoo, Project Director, Nez Perce Tribe; Deward E. Walker, Technical advisor, University of Colorado. [1st ed.] ed. Walker, Deward E. and Nez Perce Tribe. [Lapwai, Idaho: Nez Perce Tribe of Idaho,]; 1973.

## THE SEASONAL CYCLE

### WINTER:

Winter was the time of year when there was the least movement and food gathering activity. Indians ate mostly stored foods (dried fish, roots and berries) supplemented by an occasional

deer or elk driven into the lowlands by snowfall.

In most areas there were permanent winter village sites in river valleys where there was firewood and shelter from the wind. Many of these villages were occupied for generations.

Manufacture and repair of tools and clothing occupied much of the winter. Storytelling and ceremonies also took place, making it a sacred season in some areas.

### **EARLY SPRING:**

When stored foods were running out and before late spring fishing and gathering could begin in earnest, Columbia Plateau Indians faced the time of greatest food scarcity. In some years this meant actual famine, although often it only meant that the large winter camps had to be broken into smaller groups; small family groups went off in different directions to hunt and to gather the few plant shoots appearing above ground. These small groups had a better chance of finding foods and would be less likely to over hunt or over pick an area, thus protecting both themselves and their environment.

### **LATE SPRING AND SUMMER:**

In mid-April or May food became more abundant. The fish runs increased and root crops began to ripen. First-salmon ceremonies and root feasts marked the beginning of this season of plenty. Large groups of people, sometimes from several different tribes, would gather at accustomed fishing spots along the major rivers and streams. While men fished, women went to the marshes, flatlands and hillsides to gather roots, such as camas. As the summer progressed, various food became available.

The Cayuse shared fishing, hunting, and plant-collecting lands with the Umatilla, Walla Walla, and Nez Perce throughout the Blue Mountains.

The middle of summer was marked by a slowdown in food gathering and more emphasis on social events. Dancing, gambling and trading brought Indians from many tribes together and often led to intermarriages that created more permanent alliances between tribes.

### **FALL:**

After the last big migrations of salmon, most tribes split into smaller groups and headed for favorite spots in the hills and mountains. The women gathered berries while the men hunted. This was the last chance to gather fresh foods before winter and much time was spent in preparing for the coming season. Hides were readied for tanning, wood and mats were gathered for house repair, and the last game and berries were dried. As the first snows began to fall, the scattered groups gathered together in winter villages where they began preparations for the coming spring.

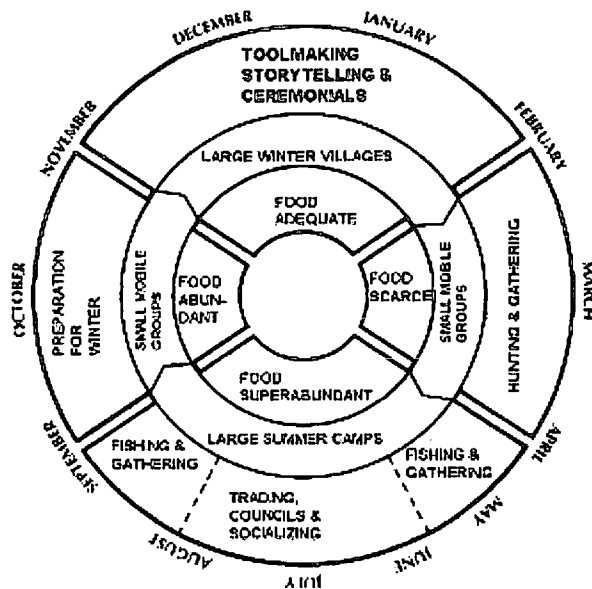

**NEZ PERCE NAMES FOR THE MONTHS:**

The Nez Perce Indians made their living according to the seasons: El-weht (Spring); Ta-yum (Summer); Sekh-nihm (Fall); A-nihm (Winter).

JANUARY---We-lu-poop. Season of cold weather.

FEBRUARY--Ah-la-tah-mahl. Season of hard time to build fire.

MARCH----Lah-te-tahl. Beginning of blossoming flowers season.

APRIL-----Keh-khee-tahl. First harvest of roots known as keh-kheet.

MAY-----Ah-pah-ahl. Season of the making of Up-pa (baked loaf) made from ground Khouse.

JUNE-----Toose-te-ma-sah-tahl. Season of migrating to higher elevation to dig the roots.

JULY-----Heel-lul. Season of melting snow in the mountains.

AUGUST----Tah-ya-ahl. Season of midsummer (Ta-Yum) hot weather. It is also referred to as Wa-wa-mai-kahl, when the salmon reach the canyon streams or upper tributaries to spawn.

SEPTEMBER-Pe-khoon-mai-kahl. Season of the fall salmon run going up stream or when the fingerlings journey down river to the ocean.

OCTOBER---Hope-lul. Season when Tamrack needles are shedding and the trees turn color.

NOVEMBER--Sekh-le-wahl. Season of shedding leaves.

DECEMBER--Ha-oo-khoy. Season of the fetus in the womb of the deer.

Source of Nez Perce names for months:

*Slickpoo, Allen P. Noon nee-me-poo (We, the Nez Perces): Culture and history of the Nez Perces. Allen P. Slickpoo, Project Director, Nez Perce Tribe; Deward E. Walker, Technical advisor, University of Colorado. [1st ed.] ed. Walker, Deward E. and Nez Perce Tribe. [Lapwai, Idaho: Nez Perce Tribe of Idaho,]; 1973.*

## INDIAN TRADE NETWORK

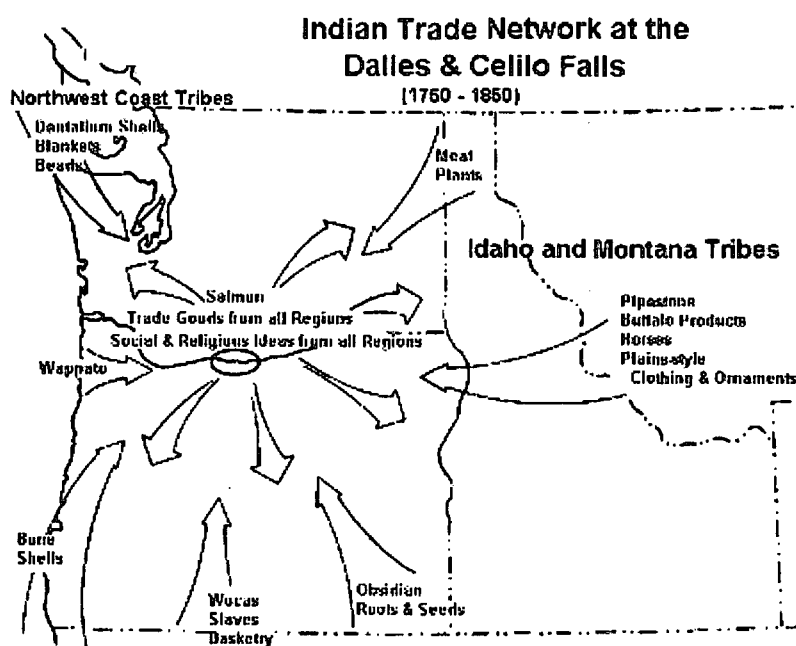

BEST COPY AVAILABLE

# TULE MAT LONG HOUSE

Variations on the Plateau Area mat longhouse include the smaller (and less common, in early times) circular mat lodge, and the skin longhouse, used for celebrations. The circular lodges, which held only one or two families, were about 25 feet in diameter, while the longhouses were always about 15 feet wide and up to 80 feet (eight fires) long (any longer and they would get too smoky).

Another kind of housing found in all Plateau settlements was the circular semi-underground shelter. Separate structures were built for men and pubescent girls (Spinden). Although smaller, these shelters were not unlike the Klamath winter dwellings. Plateau dwellings are described by Slickpoo; and by Walker (1978).

The mat longhouse, used in the Columbia Plateau Area, was constructed similarly to a tepee. A series of pole tripods were set up with double ridgepoles stretched between them. More poles were leaned against the ridgepole and the whole structure was then covered with mats. Earth was piled along the bottom for insulation. There were often several doorways along the length of the house. The longhouses were as long as the plank houses of western Oregon and held a number of families who chose a leader and acted as a group. Family fireplaces were lined down the center of the house eight to ten feet apart.

# EASTERN OREGON WINTER DWELLINGS

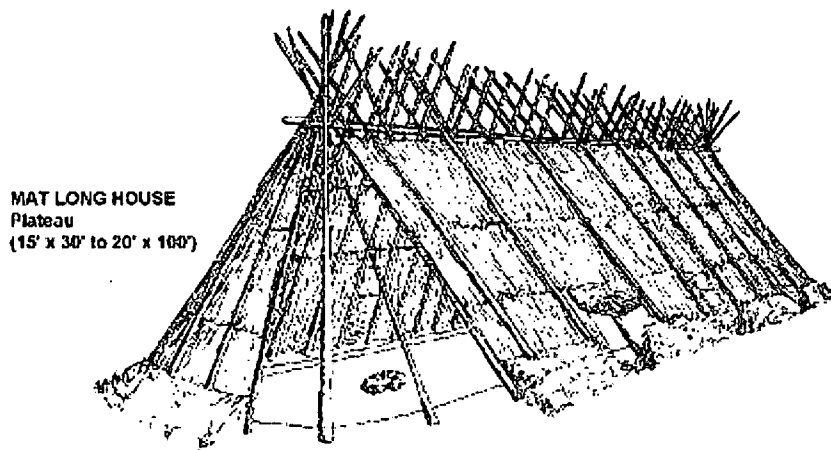

The mat longhouse, used in the Columbia Plateau Area, was constructed similarly to a tipi. A series of pole tripods were set up with double ridgepoles stretched between them. More poles were leaned against the ridgepole and the whole structure was then covered with mats. Earth was piled along the bottom for insulation. There were often several doorways along the length of the house. The longhouses were as long as the plank houses of western Oregon and held a

number of families who chose a leader and acted as a group. Family fireplaces were lined down the center of the house eight to ten feet apart.



# OREGON TRAIL TEACHER'S GUIDE

## SECTION THREE - THE MISSIONARIES

### MISSIONARY FACTS

In 1831, two neighboring tribes west of the Rocky Mountains, the Nez Perce and the Flathead, sent a delegation of their tribesmen to St. Louis, Missouri to seek the white man's religion. Although their understanding of Christianity was slight and confused, they were interested in learning more about it. They sought this white man's religion because, in their minds, it explained the great power possessed by the whites: if they could acquire Christianity, it would increase the power they already had.

This call from the West was immediately heard by various churches in the United States. Several missionary organizations became active in finding men and women to send to the Pacific Northwest as missionaries. Among them were the Missions Society of the Methodist Church; the Roman Catholic Order of the Society of Jesus, and the American Board of Commissioners for Foreign Missions, then supported by the Presbyterian, Congregational, and Dutch Reformed Churches.

The first to respond was the Methodist's Mission Society. In 1834 Jason Lee and four associates joined the Wyeth Expedition and headed for the Northwest. Lee selected a site in the Willamette Valley, and a mission was established close to present-day Salem, Oregon. Reinforced by 13 new workers in 1836 and 50 more in 1838, the Methodists began to build missions at The Dalles, the Clatsop Plains, Fort Nisqually, the Falls of the Willamette, and Chemeketa--now Salem. Their work among these coastal tribes was not very successful. New diseases brought by the whites were fatal to these tribes, and consequently the number of Indians along the Willamette and lower valleys was rapidly declining.

As early as 1834 French Canadian employees of the Hudson's Bay Company had petitioned the Catholic Bishop in western Canada for priests. At first the Hudson's Bay company refused to help priests come to the Oregon country, but in 1838 it agreed to transport Catholic missionaries across the Rockies provided that no missions were established south of the Columbia River. The Reverend Blanchet became the vicar-general of the new area. He was joined at Fort Vancouver by Father Modeste Demers. The restriction of where they could establish missions was eventually removed and Catholic missions sprung up throughout the Oregon country.

In 1836, Marcus Whitman and the Reverend Henry Spalding answered the call from the American Board of Commissioners for Foreign Missions. They located their missions at the site of the Cayuse Indian tribe (Whitman Mission) and the Nez Perce tribe (Lapwai). For 11 years

they worked among the Indians. Then, in a time of troubles when two opposing forces failed to understand each other, the Whitman Mission ended in violence.

The missions represented one aspect of American expansion into the West.

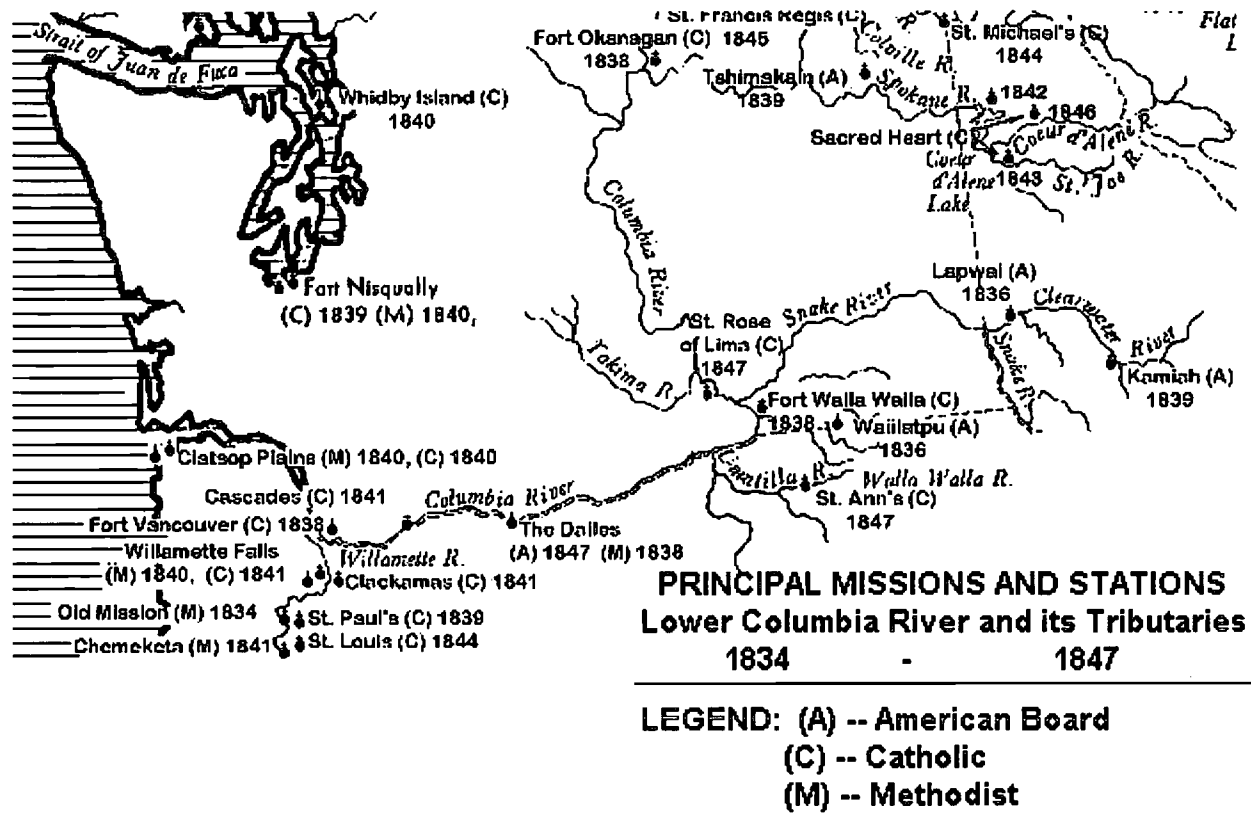

BEST COPY AVAILABLE

# OREGON TRAIL TEACHER'S GUIDE

## SECTION FOUR - PIONEERS

### PIONEER ODDITIES

Interesting facts about pioneers and their way of life.

1. The pioneers walked the Oregon Trail, but have you ever thought how many shoes were worn out by the time they reached Oregon?

According to the diary of May Ellen Murdock Compton, a 1853 emigrant, she started from Independence with ten brand new pairs of shoes and wore all of them out except the last pair. She saved this pair for the Oregon Country by walking barefoot over the last miles of her journey.

2. Some wagon trains painted their wagon canvas covers a bright red or blue. This way the individual wagons would know which group of wagons they belonged.
3. Pioneers had what they called a "Roadside Telegraph." Pioneers would write messages on anything that was available to communicate with other wagon trains. "Anything available" meant cloth scraps, animal skulls, rocks, bark, leaves, etc. Some places were "Prairie Post Offices" meaning there were a number of messages that had been left at that spot for others.
4. 1852 was the "Year of the Bloomer," although few women emigrants wore this new fashion item. The bloomer offered a woman the chance to become more practical in regard to attire during their overland journey. Mariett Foster Cummings chose to wear bloomers to avoid the mud. Eliza Ann McAuley and her sister dressed in the height of fashion as they wore bloomers with light calf-skin top boots for wading through mud and sand.
5. It took roughly \$800-\$1,000 to obtain a proper outfit (wagon, food, clothing, etc.) and enough supplies to live a whole year without planting or harvesting a crop. Some families saved for three to five years before being able to begin their trip west.
6. The idiom, "Going off half-cocked," can be traced back to the safety device on most muzzle loader guns. In theory, the "half cocked" position on the gun would prevent the hammer from falling all the way, causing the gun to shoot. Obviously,

this safety device did not always work.

7. Of the known deaths along the Oregon Trail, cholera was the leading cause of death. The present day state of Nebraska was the deadliest state for cholera. Ninety-six percent of all cholera deaths occurred by the time the emigrants reached South Pass.
8. Toilet facilities were for the most part, not mentioned in any journals written along the Oregon Trail. But, according to emigrant Charlotte Pengra, one trail-side rest area looked more like a communal ditch. There are suggestions that the full skirts worn by most ladies acted as shields or "curtains of modesty" for this purpose. Obviously, bloomers would not provide this advantage.
9. Fine china was packed in barrels of flour and cornmeal. This packing technique was designed to prevent family heirlooms from being destroyed during the journey. In theory this was a great idea, but there was one serious drawback --usually, the travelers had to eat the flour and cornmeal during the trip, and most of the dishes ended up breaking anyway and had to be discarded along the trail.
10. It appears that one out of every five overland women were in some stage of pregnancy during the trip and virtually every married woman traveled with small children. This clearly illustrates the physical demands endured by women during their journey.
11. Women were considered young ladies when they reached the age of 13 or 14, and it was common for a 15 year old woman to be married. The average age for a woman to get married during the mid-1800's was 20, and the average age for men to be married was 25.
12. The disease "cholera" was first reported in the United States during the years of 1832-1834. It disappeared until the winter of 1849 and then continued to be a problem for several years as it spread throughout the major American cities. St. Louis lost a tenth of its population to this disease. Many pioneers thought that by going west they might be able to escape this disease. But as one emigrant diary read, "The road from Independence to Fort Laramie is a grave-yard." Another emigrant put the number of burials at 1500 to 2,000 at this point on the trail, while yet another put the death total at around 5,000.
13. According to author John Faragher, "Children along the trail were pretty much allowed to shift for themselves, to grow as they might, with relatively little parental or maternal involvement in the process."
14. Portraits and photographs of dead family members, particularly infants and young children were highly cherished. This became a way of holding onto a life too soon snuffed out. In fact, it was not uncommon for a parent to pose with a dead infant in their arms and later place this picture on their mantel or table.

15. Over 60 percent of all male heads of households traveling the trail were farmers. Physicians, lawyers, teachers, and other professional made up 12 percent, while craftsmen and merchants made up 20 percent.
16. In most wagon train groups, once every two weeks, the women spent a full day doing the wash. As one emigrant woman wrote, "Camilia and I both burnt our arms very badly while washing. They were red and swollen and painful as though scalded with boiling water. I do not see that there is anyway of preventing it, for everything has to be done in the wind and sun."

## The True Story of the Sagers



There have been several fictional stories and books written about the Sager family. These fictional accounts generally have been accepted as truth. The following is a brief factual account of the Sager story. A more complete, accurate account can be found in both *SHALLOW GRAVE AT WAILATPU* by Thompson and *STOUT HEARTED SEVEN* by Frazier.

In the spring of 1844, Henry Sager packed his family and goods aboard a covered wagon and headed for the fabled land of Oregon. The Sager wagon joined the others of the emigrant train of that year and slowly the caravan pushed westward from Missouri. Mrs. Sager, already the mother of six youngsters and expecting her seventh, was not at all excited about going to the far West. She had already moved from Virginia to Ohio, then to Indiana, then to Missouri, in order to please her restless husband. Now she dreaded the thought of crossing the Rockies and making the long hazardous trip to the Pacific.

At the outset, the daily routine of breaking camp and moving the wagons into line was quickly established. But just as quickly, the Sager family was beset with difficult problems. Soon after starting out, Mrs. Sager presented her husband with a baby girl. While the mother was still regaining her strength, disaster fell upon nine year old Catherine, the oldest of the girls.

At Fort Laramie, Catherine caught her dress on an axe handle when she started to climb out of the moving wagon. She fell under the big moving wheels and her leg was broken in several places. Mr. Sager set Catherine's leg and did such a good job that Catherine had only a slight limp after it healed.

For the moment, however, the wagon box must have resembled an ambulance, with Mrs. Sager, the new baby, and Catherine all suffering from the jolts and bumps of the trail.

Yet, Catherine's accident had one good result. It brought Dr. Dagon into the lives of the Sagers. Dr. Dagon arrived after the leg had been set and checked the break. His help was to become even more important as the wagons moved westward. By the time the emigrants reached South Pass, the gateway through the Rocky Mountains, Henry Sager was seriously ill with fever. His health steadily grew worse despite Dr. Dagon's treatment. By the time the old fur rendezvous of Green River was reached, the Sagers sorrowfully buried their father's body beside the stream.

The train had gone too far west for the Sagers to consider turning back to Missouri. Despite the fears of the unknown future, it was easier for the family to go on with the rest of the wagons. Mrs. Sager, not yet fully recovered from child birth and mourning her departed husband, now had all the responsibility for the seven children. She was not alone, however, because Captain William Shaw, who was the leader of that section of the wagon train, and Dr. Dagon made sure that the family was cared for. The doctor climbed into the wagon seat and drove the oxen the rest of the way to Oregon.

Slowly, the wagons lumbered along the Snake River and slowly, too, Mrs. Sager sank beneath the cares and sicknesses that hung on her. Overcome by illness, despair, and grief, she was not able to regain her health. She finally became delirious, and as Catherine sadly wrote, "at times perfectly insane." In the vicinity of present day Twin Falls, Idaho, Mrs. Sager said good bye to her children. She asked Dr. Dagon to take care of the orphans until they were safely in the hands of Dr. Marcus Whitman, the well known missionary in the Walla Walla Valley of what is now south-eastern Washington. Sorrowfully, the emigrants buried Mrs. Sager's body. The grief stricken children numbly climbed into the wagon, and Dr. Dagon guided the oxen toward the setting sun. The two boys, John 13 and Francisco 12, were old enough to take care of themselves. But the five girls, Catherine 9, Elizabeth 7, Matilda 5, Hannah Louise 3, and the new baby, needed the care of adults. Despite large families of their own, the women of the wagon train opened their hearts to the orphans and spared what time they could in taking care of the little girls. Several women on the train nursed the baby, so that it survived the weeks that lay ahead of them. This was only the second year that emigrants had taken their wagons all the way to the Columbia. Dr. Dagon, although he immensely enjoyed driving the wagon which had by now been reduced to a two-wheeled cart, was not particularly skilled in driving oxen over the treacherous trail of the lower Snake River. Perched on top of the cart, he urged the oxen on by swearing loudly when he thought that would help. The girls, crowded behind him, had been



taught by their parents that swearing was not proper. Every time the doctor uttered an oath, one of the girls would promptly kick him in the broad seat of his trousers to remind him of their presence.

In late October, 1844, the cart pulled into the yard of the Whitman Mission at Waiilatpu. Captain Shaw, who had ridden on ahead to alert the missionaries asked Mrs. Whitman to come outside and see her new children. When Narcissa Whitman ran out to greet the dirty, barefoot orphans, her eyes saw a pitiful sight. Dr. Dagon, his work of father and mother now ended, stood to one side of the cart. Emotion showed strongly on his face as Narcissa murmured soft words of compassion for the ragged, little girls. The two boys, overcome by weariness and relief, began to sob. Catherine, with her crippled leg, also broke into tears, and the smaller children stood dumbfounded and afraid, not knowing what would happen next.

The seven orphans had found a new home. Years later, the three oldest girls were to recall many times the loving care of the Whitmans. They were to remember too, that their survival through the wilderness was due largely to the unselfishness of Captain Shaw, Dr. Dagon, and the unnamed pioneer woman. Years later, Catherine wrote, "We were all taken care of by the company. There was not one but that would share their bread with us."

In July of the next year, Dr. Whitman obtained a court order in Oregon Territory which gave him legal custody of the children "until further arrangements could be made." But for all practical purposes, the Whitmans had found seven children and the Sager orphans had found a father and mother.

Three years after their arrival, in 1841, the Sager children again were orphaned when Marcus and Narcissa Whitman lost their lives when the Cayuse attacked the mission. The two Sager boys, John and Francisco, were also killed. While a captive of the Indians, little Hannah Louise died from sickness. The four surviving girls, after their ransom from the Indians by the Hudson's Bay Company, were moved to the Wilamette Valley in western Oregon where the American settlements were centered.

Years later, the three older girls, Catherine, Elizabeth, and Matilda, were to write and speak often of the trip westward and the events at Waiilatpu. They gave high praise to Captain Shaw, the wagon master; Dr. Dagon, who had befriended them; the emigrant women; and, of course, Dr. Marcus Whitman and his wife, Narcissa.

Appraisal of the estate of Henry Sager delivered to Marcus Whitman by Wm. Shaw on the 6th of Nov. 1844

3 yoke of oxen at @50 per yoke-----	150.00
The fore wheels of one wagon-----	13.00
One cow-----	37.50
One odd steer-----	29.00
One cow (excluding five dollars expended in procuring her from the Indians)-----	20.00
3 chains and two yokes-----	10.00

1 ax-----	2.00
1 screw plate-----	3.00
 Total-----	 262.50 (sic)

June 25, 1845

Benjamin Nichols  
Solomon Eads  
Com. B. Magruder



# OREGON TRAIL TEACHER'S GUIDE

## SECTION FIVE - SOCIAL STUDIES ACTIVITIES

### COMPARE AND CONTRAST

There were many differences between the Indian and the Pioneer. By breaking your students into small groups you can assign them a topic and have them do research on their respective topics. Suggestion: It might be a good idea to have various groups research an Indian version of life during the pioneer times or research a white man's version. Afterwards, the two versions could be presented, compared, and discussed and writings and murals depicting various topics could be shared with others in the class.

This guide contains a Compare and Contrast section that discusses cultural differences which is also included in this section. Other topics of cultural differences that would be suitable for research and sample questions for students could include the following:

#### **SHELTER:**

1. What was the primary difference between the plains and coastal Indians shelter?
2. Why did Marcus Whitman use adobe material and not wooden materials for structures built at the Whitman Mission site?
3. Describe steps necessary to construct adobe bricks.
4. What is tule or bulrush? Where is it found? What is it used for?
5. Why did the many Indians live in temporary shelters?
6. Did the Indians live in shelters during the entire year?

#### **FOOD:**

1. Did the Indians farm or cultivate any land?
2. What food did the Indians eat at different times/seasons of the year?
3. What did the pioneers eat on the trail?

4. How did the Indians make and maintain their fires? Was this method similar or different from the pioneers' method?
5. How much land did Whitman farm and what did he plant?
6. What is a grist mill? How does it work?

#### **TRANSPORTATION:**

1. How did the Indians carry or transport heavy items?
2. What type of tools and living materials did the Indians use?
3. How did the pioneers travel along the Oregon Trail?
4. What changes and improvements were made in the design of the covered wagon throughout the years of use of the Oregon Trail?
5. Did travelers along the Oregon Trail ride inside the wagons? Why or why not?
6. How did pioneers travel down the Columbia River or Gorge?
7. Did these pioneer remedies differ from those of the Indians? If so, what were the differences?
8. Which medical practices were most effective: Those used by the Indians or the whites? Why?

#### **CLOTHING:**

1. What types of clothing did the Indians wear?
2. What materials were used to construct Indian clothing?
3. What types of clothing did the pioneers wear?
4. What materials were used to construct pioneer clothing?
5. What colors of natural dyes were available to the Indians and the pioneers? What was used to produce natural dyes?
6. Which type of clothing was more durable and warmer during the winter months--The pioneer or Indian clothing?
7. Was it possible for the pioneers and Indians to obtain pre-made clothing, or was it

necessary to make all of their garments?

### **MEDICINE:**

1. What was the name given to the Indian individuals responsible for practicing medicine?
2. What type of training did these medicine people possess?
3. In Indian culture, what could ultimately happen to a medicine man if one of their patients died?
4. How much training did Pioneer doctors have in medicine? Is the training they received comparable to the training a doctor would need to practice medicine today?
5. Explain the medicine procedures that pioneers used for various illnesses. Are these procedures similar or different that would be used today for the same illnesses?

### **CULTURAL DIFFERENCES BETWEEN THE INDIANS AND PIONEERS**

1. The Indians believed that their doctors possessed wonderful faculties of conjuration and supernatural power. The missionaries knew that doctors held no supernatural powers.
2. The Indians had a custom that if a doctor could not cure a patient then the relatives could seek revenge by killing the doctor (or Medicine Man). The missionaries were saddened by death, but they did not avenge a death by killing the doctor.
3. The Indians, especially the wealthy Cayuse, practiced polygamy. The missionaries had only one wife.
4. Cayuse women, or slaves, performed all menial tasks. Missionaries tried to lessen the work load of their wives by helping with chores.
5. The Cayuse was a nomadic tribe. Their concept of land ownership differed from the whites. They had loosely defined tribal boundaries and each band, or family group, had even more loosely defined boundaries. The Cayuse hunted and gathered food from the land. Fences and agriculture were foreign to their nature. Also, work was to be done by slaves and inferior tribes. After obtaining the horse, the Cayuse became shrewd traders and, consequently, they traded more and hunted less. Missionaries glorified work. They built fences and they farmed the land. The Indians did not understand why they could not harvest anyone's crops

since they had been grown on Cayuse land.

6. The Cayuse revered the land and its natural features; everything had a meaning in their legends and religion. The missionaries used the land for cultivation and profit.
7. The Cayuse believed in dreams and magic. They thought the missionaries would bring special magic to them. When no magic appeared, they thought the missionaries were saving it all for themselves. The missionaries believed in the saving grace of Jesus Christ, and in hard work.

# THE FIRST PEOPLE IN OREGON

More than twelve thousand years ago, the land that today is known as Oregon was covered with forests, mountains, and high desert. Then people began to arrive from Asia. These people were hunters who moved from place to place to find food. Scientists have named this time in history the Paleo-Indian Period. Paleo (PAY-lee oe) means "ancient" or "long-ago." People who lived in ancient Oregon were Indians. They were the first Oregonians.

We know little about these Indians because they did not leave any written record of their lives. Scientists, however, have learned about these Indians by studying the drawings or objects that they used. These objects are called artifacts. They are the signs that scientists use to guess what the people's lives were like.

One of the most interesting clues about the early people of what is now Oregon are rock drawings. Petroglyphs are some of the earliest known art of people in the western half of the world. No one is sure exactly what the figures meant to these early people. Many of them seem to show things in their daily lives. Some show people and animals. Others might show the power of nature, such as the rain or the sun. Still others are unknown.

Some other artifacts scientists have found are stone points, which were used for spears. From these artifacts, scientists have learned that the ancient Indians were hunters. They used spears to hunt large animals that are now extinct, such as American lions, ancient bears, and giant sloths. The Indians threw spears at these animals, using a spear-thrower that helped them throw the spears harder and farther.

Another thing that scientists have learned from artifacts is that these Indians probably only lived in one place for a short time. Then they moved on, searching for food.

1. What are artifacts?

---

---

---

---

2. What kind of artifacts from the Paleo-Indian Period tell us that the Indians of this time were hunters?

---

---

---

# COMPARING INDIANS OF THE NORTHWEST

Directions: Fill in the spaces below with information about each tribe. You may need to do some library research if you do not know all of the answers.

<b>Indian Tribe</b>	<b>Where They Lived</b>	<b>Food</b>	<b>Shelter</b>	<b>Other Facts</b>
---------------------	-------------------------	-------------	----------------	--------------------

Nez Perce

Cayuse

Flathead

Blackfeet

Chinook

Walla Walla

Clatsop

Tillamook

Yakima

## FUR TRADERS AND TRAPPERS

As the 19th century dawned, the United States and Great Britain were locked in a struggle for control of North America's northern Pacific coast, a region rich in furs. By 1818 the two nations had agreed to share access to the Oregon Country, as they had come to call the region, until they could decide upon a boundary. Seven years later, in a bold move designed to anchor Britain's claim to all of Oregon, the Hudson's Bay Company--the giant fur trading organization--moved its Columbia Department headquarters from Fort George at the mouth of the Columbia to the newly established Fort Vancouver located 100 miles upstream. For the next two decades, Fort Vancouver was directed by strong-willed, capable men who built it into the fur trade capital of the Pacific coast.

The Hudson's Bay Company found itself at the center of this fur trading business. As the vagaries of fashion carried the beaver hat to the heights of popularity, the demand for that animal's fur increased enormously. From Fort Vancouver the Hudson's Bay Company sent out brigades of trappers that included from 50 to 200 men, women, and children. Trapping was hard and dangerous work, particularly because most of it was done in the winter, when animal pelts are the thickest.

The earliest trappers had adopted the Indians method of breaking into a beaver lodge and taking the animals, but soon the steel trap came into use. The trap, designed to catch the beaver by the leg, was set into shallow water. It was attached by a chain to a sharpened stake implanted in deeper water. The traps were baited with castoreum, a scent obtained from glands in the hind legs of the beaver. All this activity was going on while the trapper stood in the water, often ice-cold, so that he would not leave his scent on the bank. The curious beaver, attracted by the castoreum, stepped into the trap. The next morning the trapper skinned his catch. Back at camp, he or his Indian wife scraped the flesh from the skins and stretched them to dry. After almost a year in the wilderness, the trapping brigades, with their furs in tow, got ready to head back to Fort Vancouver. Joining up with one another, the brigades made their way to the Columbia and Fort Vancouver where the people awaited their arrival.

Now the company clerks took over, appraising the furs, paying the trappers, and preparing the furs for shipment to London. In the 1830's, silk hats were introduced. As the beaver population of the Northwest declined through over trapping, silk replaced beaver on the market. By 1860's the demand for beaver pelts had declined and the large scale commercial trapping of beavers came to an end.

At about the same time as this decline of beaver pelts occurred, American settlers were becoming attracted to the rich farm lands of Oregon's Willamette Valley. This influx of Americans eventually resulted in the division of the Oregon Country along the 49th parallel, a decision that left Fort Vancouver on American soil. For a few years the Hudson's Bay Company continued to trade with the settlers and the Indians, but trade diminished and the Company moved out in 1860.



# PACIFIC NORTHWEST FUR TRADERS QUESTIONS

1. Why were Europeans and Americans interested in Northwest coast furs?

In his voyage to the Northwest Coast, Captain Cook discovered that native Indians were willing to trade beautiful sea otter pelts for brass buttons and other pieces of metal. These pelts were also worth quite a bit of money on the other side of the ocean. The most valuable fur was the sea otter, which was worth as high as \$120 in China. Beaver and seal were also valuable.

2. What were some of the things that the natives of the region were willing to take in exchange for their furs?

At first the natives were interested in anything that was made from metal: buttons, strips of copper, tea kettles, etc. Calico cloth, beads (particularly blue beads), wool, blankets, rice, molasses, and tobacco. Later, guns, gunpowder, and liquor also became important trade items.

3. What were the names of the native tribes that lived amongst and traded with the Hudson's Bay Company?

The lower Columbia River region was populated by a family of natives, known collectively as the Chinooks. Tribal groups included the Clatsops, Klamaths, and Wahkiakums. The Quinalt and Makah inhabited the Washington coast. Still further north lived the Nootka, the Kwakiutl, the Haida, and the Tlingit.

4. Who do you think gained the most from the fur trade? From a dollar and cents standpoint, the merchants who sponsored the fur trading ventures to the Northwest coast were the real winners, if enough furs were obtained. Early on in the trade, an investment of \$10,000 to \$50,000 might gross \$150,000 to \$250,000. But the natives were shrewd traders. In most cases they obtained material goods that they could not have gotten otherwise. So viewed in this light, the natives made a "good deal" also.

5. Who was John McLoughlin?

John McLoughlin was born in Quebec in 1784 and trained as a physician near Montreal. He joined the Northwest Company as a physician at its post at Fort William. When the Northwest Company merged with the Hudson's Bay Co., McLoughlin was named head of the Columbia Department. His job was to keep peace with the Indians, squeeze Americans out of the market, and firmly establish the British claim to all of Oregon. As a businessman he was successful. He was generous to the settlers, selling them supplies and lending them credit. When the new Oregon boundaries became established, he retired and moved to Oregon. He later became an American citizen and is known as the "Father of Oregon".

# MOUNTAIN MEN

The men that searched the wild areas of the Rockies for beaver became known as the "mountain men." Many of these mountain men became known for helping to settle Oregon Country and the rest of the west. During the year of 1822, two men got their start out west as fur trappers. Jedediah Smith and Joe Meek left their mark on the Oregon Country.

Jedediah Smith explored many mountain areas during his fur trapping time. He was the first white man to cross the Sierra Mountains and also to reach California by land from the east. Trapping was dangerous. Jedediah met a bear one time and was badly clawed. One of his ears was ripped off during this encounter and was sewn back on by a fellow trapper. After ten days of recovery, Smith continued on his way. Smith was always on the lookout for new streams to trap and he probably saw or discovered more new land than any other white man. Jedediah also helped out the settlers as they were coming to the Oregon Country. He led many wagon trains over the Oregon Trail.

Joe Meek left his home when he was only 18 years old. He also made his "trapping" home in the Oregon Country as well as helping settlers find the Oregon Country. Not only was Meek a mountain man but he helped make laws when the Oregon Country was established. Later, after the Whitman Massacre, Joe Meek traveled back to Washington to convince the government to make the Oregon Country into a Territory. When this did happen, Joe Meek became the first U.S. marshal of the newly founded Oregon Territory.

Directions: Read the questions and answer in complete sentences.

1. How did Jedediah Smith and Joe Meek help the growth of the country?

---

---

---

2. Why was it dangerous to be a trapper?

---

---

3. Why do you think these mountain men would of made good leaders for the wagon trains coming west on the Oregon Trail?

---

---

---

# GO WEST!!

In 1843, more than 120 wagons gathered around Independence, Missouri. Most of these wagons were brightly painted in colors of red, green, and blue. Their canvas tops were clean and white. These people were preparing to cross the country, over mountains and rivers, to Oregon. This trip would be one of the first on the Great Emigration west. The word Emigration means to leave one country and move to another.

Why did these people want to do this? Some had heard of the rich soil found in Oregon while others just wanted some free land. Others wanted to live where there were fewer people so they could have more elbow room. But whatever their reasons were for leaving, no one could have foreseen the hardships they were about to encounter they traveled the Oregon Trail.

The Oregon Trail was almost 2,000 miles long and the trip would take about six months to complete. Leaving in May, the pioneers would get to Oregon some time in October. During that time they would have to withstand cold and wet storms as well as the heat of the desert. Rivers would be a welcome sight, for a river meant fresh water. But rivers were also problems. Pioneers would have to turn their wagons into rafts and float across. If they chose not to float the river they would attempt to ford the river by slowly crossing in a shallow section, hoping that their animals would not drown. Wagon wheels would get stuck in the mud, axles would break, wheels would come off, oxen would die from the heat and some pioneers would end up cutting their wagons in half and turning them into carts. Pioneers would freeze as they crossed the high snowcapped mountains. Cholera and influenza would take many pioneers' lives before reaching the Oregon Country. But when they did make it to their destination, the pioneers would never forget the beauty of the country they crossed.

Directions: Read the following questions and answer in complete sentences.

1. What does "emigration" mean?

---

---

2. Why do you think going to the Oregon Country was called the Great Emigration?

---

---

---

3. Imagine you are on the Oregon Trail. On the back of this paper, write a journal entry describing what you do from sunup to sundown.

# PEOPLE ON THE TRAIL

## Tabitha Brown

Tabitha Brown was from the state of Massachusetts. In 1817 she opened up a boarding house where people could buy meals and rent out rooms. Later on, in 1846, she heard others talk of the Oregon Trail. At the age of 66 years old, Tabitha packed up with her family and moved to Oregon. The trip was difficult--it took them nine long months.

Upon arriving in Oregon Country, Tabitha Brown opened up a home for children without any families. She cooked and cared for 40 children. There she taught them to sing, and how to behave properly. When Tabitha died in 1858, her home was turned into a college. It is now known as Pacific University. Today, Tabitha Brown is known as the Mother of Oregon.

## George Washington Bush

George Washington Bush was a black man who lived in the Northwest and made himself rich during a time when most black people were slaves in the South. This man became known as one of the richest pioneers who came to the Oregon Country. He raised and sold cattle and livestock in both Illinois and Missouri.

In 1844, Bush helped many families cross the Oregon Trail. He was very generous. But at this time, black people were not allowed to live in the Oregon Country so Bush helped them to move north above the Columbia River. He settled near Olympia, Washington and today this area is known as Bush Prairie. Here in his new home, Bush again gained a reputation of helping others. He was so well liked that both Washington and Oregon passed laws during the 1850's to let him live there.

Directions: Read the questions and answer them in complete sentences.

1. Why do you think Tabitha Brown is called the "Mother of Oregon?"

---

---

2. What kinds of problems do you think an older woman would have taking care of 40 children?

---

---

---

3. Why was George Bush so well liked among pioneers?

---

---

## MAKING DREAMS COME TRUE

Directions: After reading about Tabitha Brown and George Washington Bush, fill out the sections below. The third column is for you. Use the third space provided to think about any dreams, obstacles, etc. you have now or think you will have in the future.

	<b>Tabitha Brown</b>	<b>George Washington Bush</b>	<b>Me</b>
<b>Dreams:</b>			
<b>Obstacles:</b>			
<b>Strengths:</b>			
<b>Outcome:</b>			

## THE INLAND FUR TRADE COMPANY

Directions: Fill in the blanks in the following story using the vocabulary words listed below.

Dr. John McLoughlin was 1. \_\_\_\_\_ of the Hudson's Bay Company.

His house and many other buildings were inside the 2. \_\_\_\_\_ or walls of Fort Vancouver.

The 3. \_\_\_\_\_ was built as a lookout to help protect the fort. Dr. McLoughlin worked very hard to make sure that there was an 4. \_\_\_\_\_ of food and other supplies for everyone who lived at the fort.

He did not want people to be 5. \_\_\_\_\_ on England for tools and other items made of iron and steel.

He hired a 6. \_\_\_\_\_ to make tools and traps.

7. \_\_\_\_\_ were made in the bakery at the fort for the  
8. \_\_\_\_\_ of trappers to eat when they were trapping beaver.

Dr. McLoughlin and his assistant James Douglas wanted to 9. \_\_\_\_\_ the fur trade in the Pacific Northwest.

Today 10. \_\_\_\_\_ take care of the objects that Dr. McLoughlin used so long ago.

---

Answers:	1.	Chief Factor	4.	abundance	7.	sea biscuits
	2.	stockade	5.	dependent	8.	brigades
	3.	bastion	6.	blacksmith	9.	dominate
					10.	curators

---

## PIONEER LIFE

The first settlers who arrived into the Oregon Country did not waste much time--they got right down to business. The pioneers chose a sight in the wilderness to build their home. A wilderness is an area of land that is not yet lived in or settled in. They had to chop down trees, and by using whipsaws, they sawed the trees in half to form logs. They then cut small pieces out of the end of the logs. These cuts held the logs into place when they stacked them to build their log cabins. The pioneers had to fill up the holes between the logs. With what do you think they used to do this? Mud and dirt as well as small sticks were used to fill these openings. When the logs were being put in place, the settlers would cut openings for the doors and windows. The roof was made from the bark of trees. Sometimes the floors had wood planks laid down but most of the time the early settlers had mud floors.

The furniture of these log cabins was very simple. Tables and chairs were also made from logs. Beds were stuffed with straw and corn husks and these mattresses and were built into the corners of the cabin.

A homestead is where the pioneer lives as well as farms. Everyone had to work on the homestead. The children fed the chickens, gathered eggs, milked the cows and tended (worked) in the garden. They also rode horses to drive the cattle to fields where they could graze. Wood had to be chopped for the stove and for long, cold winters. Girls usually helped their mothers make and mend clothes, do the wash, and clean the house. In their spare time, boys worked in the fields. Women and men both worked all day from morning until night on the homestead.

Directions: Read the questions and answer them in complete sentences.

1. Describe the activities on a homestead.

---

---

---

2. How did pioneers spend most of their time? Why?

---

---

---

3. What do you think pioneers on a homestead did in their spare time?

---

---

---

4. How is life different now? Do you think it would of been easier to live during the times of the pioneers or today? Why?

---

---



## THE MISSIONARIES

If you had lived on the east coast of the United States during the 1830's you would have heard news of the Oregon Country and land there that was rich and plentiful. The missionaries spoke of this land and encouraged people and businesses to move to the Oregon Country. They spoke of rich farm land, fish-filled rivers, forests, and friendly Indians who only wanted to help the white settlers.

People also heard tales of Indians interested in learning more about the "Book of Life" or the Bible. Newspapers told of four Indians who had come all the way to St. Louis just to learn about the white man's religion. These Indians wanted knowledge of this power or religion and because of this desire, more missionaries started to go out west.

We now know that the missionaries that came out west had very little luck teaching the Indians about white man's religion. Regardless, these missionaries spread the news about the Oregon Country to the people back east and this eventually brought many new settlers to the Oregon Country via the Oregon Trail.

The first missionary to come out west was a man named Jason Lee. Jason Lee made the journey to the Oregon Country and settled in the Willamette Valley. He started a school in the valley and today it is known as Willamette University.

Marcus and Narcissa Whitman were also missionaries who came out to the Oregon Country. They set up their mission along the Walla Walla river where the Cayuse Indians lived. A mission is where missionaries live and teach others about their religion. The Whitmans lived there for almost 11 years trying to teach the Indians how to farm and about their religion. Since Whitman was a doctor, he tried to give medical help when the Indians were in need. Still, the Indians became sick with "White Man's" diseases such as small pox and the measles. Whitman could not help them and the Indians blamed him and killed him for their getting sick and dying.

1. Who was Jason Lee?

---

---

2. Why did missionaries want to go to the Oregon Country?

---

---

---

3. Why did the Oregon Country seem like a good place to start a business?

---

---

---

---

# OREGON TRAIL--MISSIONARIES

## Word Jumble and Vocabulary

**DIRECTIONS:** Use the word list to help you unscramble the following words. Then use the space below to put them in alphabetical order.

1. TTESRAONSEHH \_\_\_\_\_
2. NENIAC T \_\_\_\_\_
3. EWP \_\_\_\_\_
4. LWMLASI \_\_\_\_\_
5. RACSOTEN \_\_\_\_\_
6. SISOMIN \_\_\_\_\_
7. GALSNI P \_\_\_\_\_
8. RMASYIINOS \_\_\_\_\_
9. LTLIRIGMS \_\_\_\_\_
10. TRECAHITRECU \_\_\_\_\_

### Alphabetical Order:

1. \_\_\_\_\_
2. \_\_\_\_\_
3. \_\_\_\_\_
4. \_\_\_\_\_
5. \_\_\_\_\_
6. \_\_\_\_\_
7. \_\_\_\_\_
8. \_\_\_\_\_
9. \_\_\_\_\_
10. \_\_\_\_\_

## OREGON TRAIL--WAGONS WESTWARD

### Matching Exercise/Vocabulary

**DIRECTIONS:** Place the number of the word on the left in front of its definition letter on the right.

- |                  |   |
|------------------|---|
| 1. Ferry         | _____ a. Person who lives on the frontier                         |
| 2. Migration     | _____ b. The group of people who make the laws                    |
| 3. Patriotic     | _____ c. To expand a story beyond the grounds of truth            |
| 4. Abandon       | _____ d. A boat used to carry people and goods across the water   |
| 5. Frontiersman  | _____ e. A great eagerness to come to the Oregon Country to live  |
| 6. Oregon Fever  | _____ f. Feeling love of and support for one's country            |
| 7. Blaze a trail | _____ g. To leave, especially because of trouble or danger        |
| 8. Exaggerate    | _____ h. A person who is among the first to settle in a place     |
| 9. Congress      | _____ I. Movement from one place to another                       |
| 10. Pioneer      | _____ j. A person who settles in a new country                    |
| 11. Settler      | _____ k. Mark a new trail by cutting notches in the bark of trees |

**Answers:** 1=d 2=I 3=f 4=g 5=a 6=c 7=k 8=c 9=b 10=h 11=j

# FORT VANCOUVER: THE INLAND FUR TRADE

Directions: Study the diagram of Fort Vancouver as it was in 1845. Then read and answer the following questions.

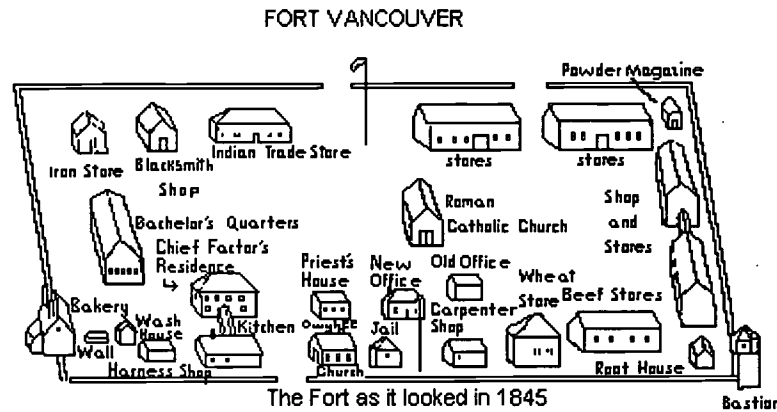

1. Circle the building where Dr. John McLoughlin lived.
2. Hudson's Bay point blankets, cloth, beads, and many other things were sold at the fort. Put a square around the building where this activity took place.
3. Put a triangle around the building where people made wagon wheels, beaver traps, and other tools out of iron and steel.
4. What do you think was kept in the building labeled "stores?"
5. Who stayed in the building labeled "Bachelor's Quarters?"
6. What is a "powder magazine?"
7. What was the "bastion" used for?
8. If you could add more buildings to the fort, where would you put them and what would you call them? Why?

BEST COPY AVAILABLE

# DISCOVER THE COLUMBIA RIVER!

Game Rules: Place your marker on "Go Discovery!" Roll the die and move your marker. Follow the directions for the space you land on. Keep track of the points you receive and try to beat your opponent. You must land on the "Discover the Columbia" square exactly. If you roll over, stay where you are. May the best explorer win!

"GO DISCOVERY!"	2 POINTS. YOU SAILED PAST CALIFORNIA MISSION, SAN JUAN	1 POINT. TRADED WITH FRIENDLY INDIANS	BOATS ATTACKED BY SPANISH FLEET. GO BACK 3 SPACES	3 POINTS. FOUND LOST EXPLORER AND WAS GIVEN A MAP TO COLUMBIA RIVER
ATTEMPTED MUTINY ABOARD YOUR SHIP, LOSE 1 POINT	FOG AND BLUSTERY WEATHER. LOSE 1 TURN	TRADE FOR TWO OTTER PELTS. 1 POINT	SPEND WINTER ON A DESERTED ISLAND. RETURN TO START	SHIP MAKES GOOD TIME IN WIND. 2 POINTS
WATCH OUT ROCKS! GREAT JOB, CAPTAIN; RECEIVE 3 POINTS	SCURVY!!! NEED FRESH FRUIT. LOSE 1 POINT	NATIVE INDIANS GIVE YOU FRESH FRUIT	TRADE FOR FOUR BEAVER PELTS. 3 POINTS	STORM BLEW YOU OFF COURSE! ROLL THE DIE AND IF IT IS ODD NUMBER, LOSE 1 POINT
IT'S YOUR B-DAY! CREW LIKES YOU SO YOU RECEIVE 2 POINTS	SAILCLOTH IN NEED OF REPAIR. LOSE 1 POINT	TRADE FOR FIVE OTTER PELTS. RECEIVE 3 POINTS	A SCHOOL OF SALMON WAS CAUGHT. RECEIVE 2 POINTS	ATTACKED BY INDIANS. YOU MANAGED TO ESCAPE. GREAT JOB! RECEIVE 2 POINTS
MAST BREAKS AND HITS YOU ON HEAD. LOSE ONE TURN	TRADING GOODS LOST OVERBOARD. OH NO! LOSE 1 POINT	FOOD SUPPLY LOW. GIVE ONE POINT TO OPPONENT	SEA SICKNESS, YOUR CREW NEEDS REST. LOSE 1 POINT	CAPTAIN SAILED ASHORE AND GOT MEDICINE FROM INDIANS. 3 POINTS
ENTER RIVER. IS IT THE RIGHT ONE? RECEIVE 2 POINTS	TRADE FOR MUSKRAT HIDES. RECEIVE 1 POINT	INDIANS TRY TO BOARD SHIP. GO BACK 5 SPACES	MAN OVERBOARD BUT YOU SKILLS SAVED HIM. 1 POINT	SAILED TO SANDWICH ISLANDS AND THE FIRST MATE DIES. OH WELL, LOSE 1 POINT
TRADE WITH INDIANS AND THEY SHOW YOU WAY TO COLUMBIA. RECEIVE 5 POINTS	AHOY CAPTAIN! COULD THIS BE IT? RECEIVE 2 POINTS FOR GOOD SAILING	SHIP RAN INTO SANDBAR. LOSE 1 POINT AS CREW TRIES TO GET OFF SANDBAR	FOG AND HIGH WINDS BLOW YOU WAY OFF COURSE. ODD ROLL DIE WILL LOSE YOU 1 POINT	INDIANS WANT BLUE BEADS, YOU ONLY HAVE RED ONES. WILL THEY ACCEPT FLINT & STEEL? EVEN ROLL OF DIE GET YOU 2 POINTS
IGNORE ADVICE. RIVER ENTRANCE IS OVER THERE. LOSE 1 POINT	FRESH WATER COMING TOWARDS YOU. YOUR LOOKOUT TELLS YOU THIS IS IT. GET 3 POINTS	TRADE FOR CANOES. GET 2 POINTS AS YOU (CAPTAIN) SCOUT AHEAD VERY BRAVELY	FIND PLENTY OF FOOD. YOUR CREW'S HAPPY. SUCH A NICE CAPTAIN! 3 POINTS. THIS IS IT! THE COLUMBIA RIVER	FOR SURE. HOW DO I KNOW? BECAUSE I'M CAPTAIN THAT'S HOW! 10 POINTS. DISCOVER THE COLUMBIA!

# OREGON TRAIL TEACHER'S GUIDE

## SECTION SIX - MAPS

Using maps to introduce or reinforce information is a great teaching aid. Following are a number of possible activities in which maps could be utilized in the classroom:

1. A map showing the different Indian tribes is included under the Indian section of the Teacher's Guide. Have students plot geographic locations of these tribes onto their own maps. Afterwards, have students perform research on the tribes looking for cultural differences between various tribes and research histories. Compare and discuss.
2. Obtain a map or produce one of the United States from Fort Hall to the Pacific Coast. As you read from the Oregon Trail diary each day, have students plot the daily travels directly onto the map. By the end of the school year there could be the complete Oregon Trail drawn onto the map. Also, have individual maps that students could plot the travels. These individual maps could be filed inside their own Oregon Trail folders.
3. Research various types of animals that lived along the trail. Some examples might be: coyote, bullsnake, cottontail rabbit, ducks, Canada geese, garter snake, gophers, Columbian ground squirrels, Eastern grey squirrels, meadowlark, robins, magpies, crow, deer, buffalo, rattlesnake, black bears, and red winged blackbird. Draw maps resembling a given location and its surrounding area, and using various symbols, note the locations of animal sightings onto the map. Also, habitat locations could be noted. An expansion to this activity might include the development of land around the mission site such as nearby neighborhoods, roadways, and malls. Related questions dealing with current development, possible community controls, possible further growth, further planned development problems could lead to continued discussions about land use and planning for further growth.
4. A copy of the Whitman Mission site is provided under this section. Have students draw their own maps of the mission. They should include a map key and label all areas.
5. A copy of Fort Vancouver is provided under this section. You will find a worksheet in the Social Studies section that is used in conjunction with this map.
6. Study vegetation and rainfall maps of states along the Oregon trail. Have students

transfer these data onto blank state maps. Compare existing vegetation to the existing rainfall and determine whether or not any relationships or patterns in vegetation and precipitation emerge. With regard to precipitation and available vegetation, what states and regions might have been the most difficult to travel through? The easiest? Why?

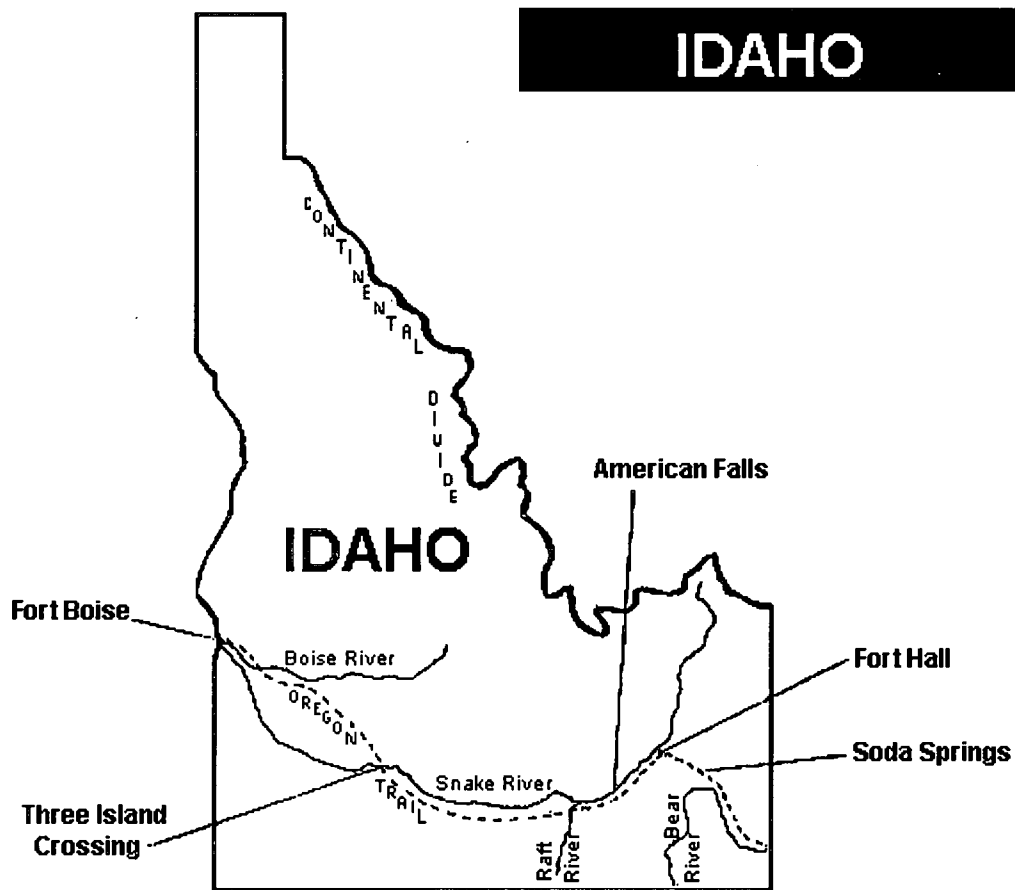

BEST COPY AVAILABLE



**OREGON AND WASHINGTON**

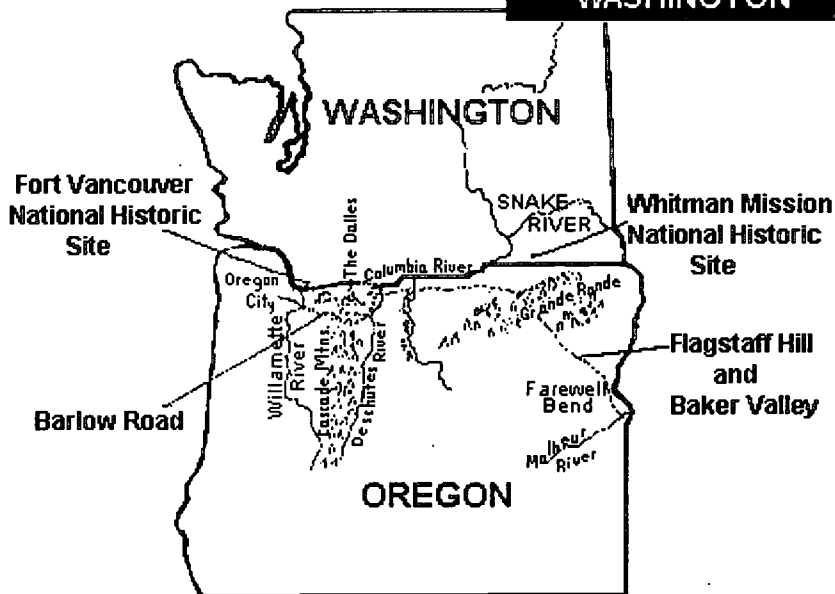

**FORT VANCOUVER**

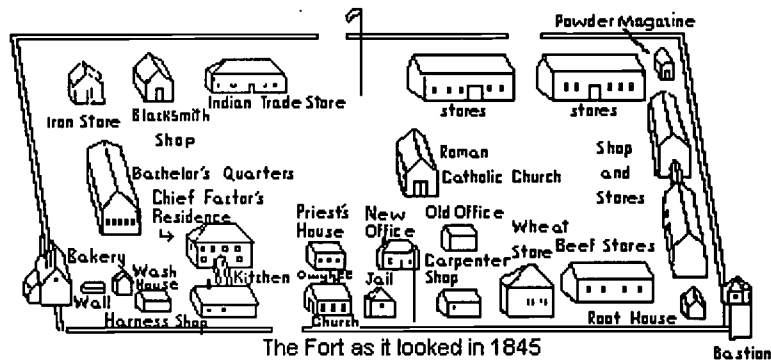

BEST COPY AVAILABLE

# Whitman Mission National Historic Site

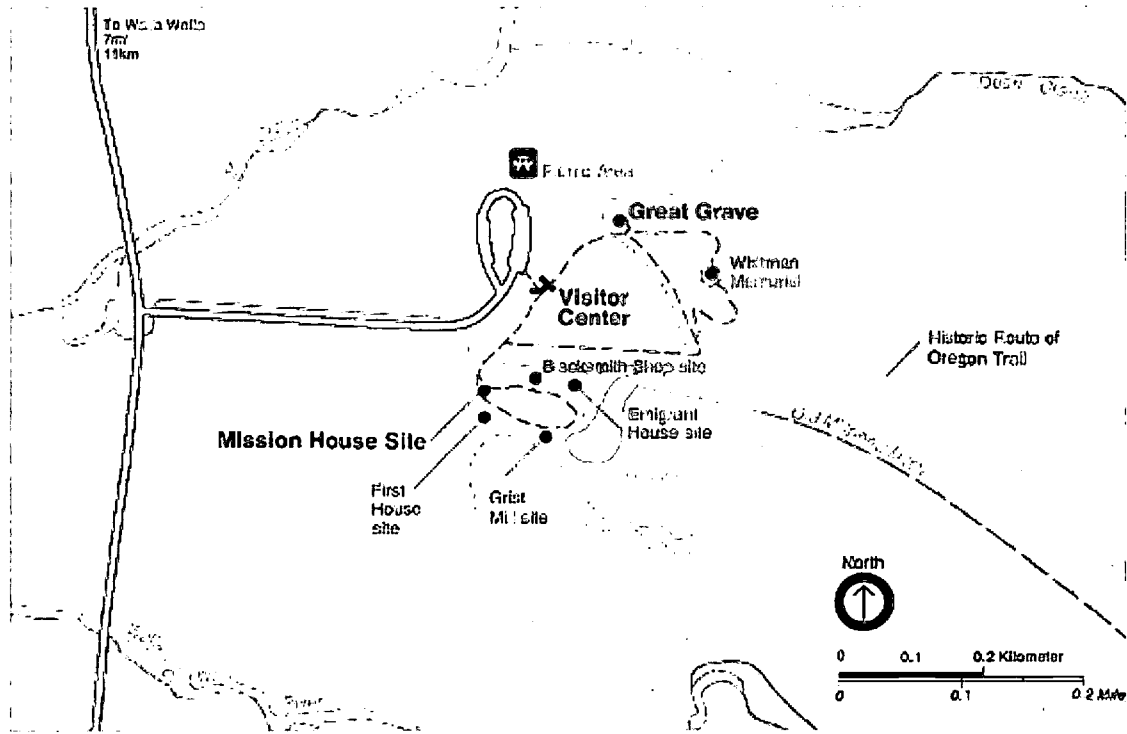

# Oregon Trail



BEST COPY AVAILABLE

# OREGON TRAIL TEACHER'S GUIDE

## SECTION SEVEN - LANGUAGE ARTS

### WRITING

Writing ideas are abundant regarding the Oregon Trail. The ideas below are just a sample of what can be done to generate ideas in order to get students started writing on this general theme.

1. Narcissa Whitman constantly wrote to her family and friends. Either read aloud to students or have students read some of the letters that Narcissa wrote herself. This will enable students to understand the basic idea of what Narcissa wrote about to others, how she felt about events in her life, etc. Have students pretend that they are Narcissa or Marcus Whitman and encourage students to write their own personal letters home. When letters are completed, they could be exchanged with another student and responses could also be generated. A continuous dialogue could develop throughout the school year.
2. During the winter months, read from the book, *Coyote Was Going There*, by Jarold Ramsey. Have students make up and write down their own stories and legends. ("Coyote Stories" are stories or tales of a particular character in Indian Legends and should be told only during the slack time of winter. It is said that, "A snake will crawl up your leg" if told during other seasons.)
3. In the appendix there are Nez Perce language pages. Utilize these and have students formulate stories using the words provided in Nez Perce. These Indian words could be written in combination with the English language. Stories could be developed as an Indian legend, if desired.
4. Have students write short stories (individually or as a group project) and then substitute sign language for written words. Students can make up the sign language and perform stories in front of the class (using sign language only). See if other students can figure out the story line.
5. Perform a skit or a play about pioneer or Indian life. Props could be designed and constructed for art activity and music could be taught during music class (if possible to incorporate with other curriculum).
6. Have students write reports on occupations of yesterday. Obviously, historical

occupations were different than today, due in part, to advances in technology. A brainstorming session, followed by a library research activity session could begin this assignment. A variation would be to discuss and develop papers dealing with occupations of today that possibly will not be necessary in another hundred years.

7. Discuss necessary ingredients and steps involved in the preparation of traditional pioneer and Indian foods. Have students write about cooking techniques, create recipes, and design steps for preparation and cooking of their dishes. Some pioneer food recipes are included in the appendix.
8. Since Indians had no poetry, have students create songs that express their feelings about nature and the seasons.
9. Read the poem PIONEER by Beulah Hastings Wilson. Have students look up any words which they are not familiar with in the dictionary. Then in groups of two or three have them write down the meaning of the poem.

### PIONEER

His beard was grizzled, his coat was frayed  
And his wagon's cloth had long been grayed.  
His cumbersome oxen bawled their disdain,  
And terror awaited him on the next plain.

Loved ones died and he mourned near the ground  
As he buried his dead in their lonely mounds,  
And hearing the children wail at night  
He read his bible by the fire's pale light.

He left me this rich heritage:  
His faith in God, his enduring grace,  
His rusty gun and his oxen bell  
And these words he shouted, I cherish still:

"Westward, Ho! --on and on,  
Safely home to Washington!"

*Beulah Hastings Wilson*

10. "Spring On the Prairie":

Read the passage describing Spring on the Prairie from "Little House on the Prairie" to the students. Identify adjectives and the nouns that are described. Brainstorm adjectives for the other seasons on a large sheet of butcher paper.

Using the adjectives on the butcher paper, have students complete the paragraph (bottom of page) to describe another season such as Fall, Winter, or Summer.

Spring On the Prairie  
by  
Laura Ingalls Wilder

Spring had come. The warm winds smelled exciting, and all outdoors was large and bright and sweet. Big white shining clouds floated high up in the clear space. Their shadows floated over the prairie. Their shadows were thin and brown, and all the rest of the prairie was the pale, soft colors of dead grasses.

\_\_\_\_\_ on the Prairie  
by \_\_\_\_\_  
\_\_\_\_\_ had come. The \_\_\_\_\_ winds smelled  
\_\_\_\_\_, and all outdoors was \_\_\_\_\_ and \_\_\_\_\_ and  
\_\_\_\_\_. \_\_\_\_\_ clouds  
\_\_\_\_\_ floated high up in the \_\_\_\_\_ space. Their shadows  
floated \_\_\_\_\_. Their shadows were  
\_\_\_\_\_, and all the rest of the  
prairie was \_\_\_\_\_  
\_\_\_\_\_  
\_\_\_\_\_.

11. Have students create and keep a diary. Remind students that a diary is very personal. Diaries may include special events in which students are involved with, news about friends and family, how they feel about important world happenings, original songs or poems, and dreams or plans about the future. Above all, stress that they should enjoy what they write in their diary. Review with them the importance of diaries that the pioneers place upon them to preserve family history. They can also do the same. Some things to do with diaries would be:
12. Have each student decorate a cover for their diary.
13. With the help of parents or other relatives, students can complete a simple family tree.
14. Students can make precise measurements when they create the cover for their diary. Measure not only in standard measurement but also in metric measurement and then compare.
15. Students can follow written or oral directions, and complete tasks in a sequence.

They can then write entries in their diaries based on these instructions.

16. Borrow copies of actual overland diaries from the library. Have students read passages from these diaries to understand the overall idea of what was written and included in the diaries. They can then tell stories to younger children based on these diaries. Possibly make up stories.
17. Discuss the vast changes in information processing since the days of the Oregon Trail when information was recorded in notebooks with pen and pencil. You can have some students do research on when the first typewriter was invented. Who invented the first machine to record sound? When did the first computers come into general use? When did the first camera become available to take pictures of ordinary people? Relate all of these to the Oregon Trail and the lack of these products at that time. Show the progress that we have made in preserving and recording history. Ask students what events or important discoveries of today will stand out and be re-discovered 100-150 years from now. Why?
18. Set up a learning center where you have placed copies of pioneer diaries. At the same time, have a blank book or notebook where students can write down their thoughts through out the day. Inform them that they can either write about classroom events or something personal.
19. As a letter writing activity, have students establish pen pals with students in cities along the Oregon Trail. Have a class map with everyone locating and marking their city and pen pal along the trail.

## **DO WE GO, OR STAY?**

### **Editorials saying: "Go to Oregon!"**

**St. Louis Gazette:** The Rocky Mountains can be crossed by wagons and families. There is no obstruction the whole route that any person would dare call a mountain. Even delicate missionary women have crossed the mountains with no ill effects.

**Missouri Gazette:** The Indians are hostile, true, but overlanders traveling together in large wagon trains are safe. In all probability they would not meet with an Indian to interrupt their progress. The army has forts and soldiers to protect travelers and more will be provided.

**New Orleans Daily Picayune:** Those bound for Oregon are Pioneers, like those of Israel that followed Moses through the wilderness. Going to Oregon is also Patriotic. It is our manifest destiny to settle the west.

**St. Louis Gazette:** In Oregon, there are spacious, fertile valleys where good crops can be grown, and free land is available. Although there is still land to be had back east, prices are rising and economic conditions are poor. No one need starve on the overland journey if they plan carefully. Provisions can be taken to last for months, and game is plentiful. In fact, the health of overlanders should improve in the great outdoors.

### **Editorials saying: "Do not go to Oregon!"**

**North American Review:** Why go to Oregon to get land? An Illinois farm of the finest land would be far superior.

**Daily Missouri Republican:** Families with wagons will never be able to cross the mountains. Men should not subject their wives and children to all degrees of suffering.

**New Orleans Weekly Bulletin:** The Indians in the west are hostile. The wagon trains would be in constant jeopardy.

**The New York Aurora:** Most of their overlanders and their animals will die of starvation and exposure in the vast desert areas of the west. It is madness and a folly to attempt a trip to Oregon.

**Liverpool Times:** The country is expanding too fast. Besides, the Oregon Country is claimed by the British. If war comes it would be impossible to defend it.



## A FAMILY WEIGHS THE PROS AND CONS

Directions: Read the attached page which has editorials showing the pros and cons for going to the Oregon Country. Discuss these pros and cons. Where do you feel your family would stand on going to the Oregon Country? Would they go? Why or why not? What would your reaction be to their decision?

I think my family would have gone to Oregon because:

---

---

---

---

---

My reaction:

---

---

---

---

---

I think my family would not have gone to Oregon because:

---

---

---

---

---

My reaction:

---

---

---

---

---

Write an editorial of your own describing why you should or should not go to the Oregon Country. Back your editorial up with facts or realistic views.

# SIGN LANGUAGE ON THE PLAINS

Many different languages were spoken among Indians. Because of this situation, Native Americans often used sign language to communicate with each other.

Part 1. Pretend that you are a pioneer and have come across a group of Indians. In order to communicate, you must use sign language. In the space below write down words and sentences which you would like to communicate to the Indians.

---

---

---

---

---

Part 2. How would you communicate your message to the Indians? Develop and practice communicating your sentences and ideas using a sign language, which you will make up. Remember, you can leave out words such as: The, a, it, and, at, etc.

---

---

---

---

---

Part 3. Share your language with a friend. Can your friend understand what you are trying to say? Improve your sign language and practice if your friend cannot understand you. Share your sign language with the class.

# LITERATURE

There is an abundant supply of literature available that is related to the Oregon Trail theme. A couple of excellent books which you can use as a literature based reading program are:

Sarah Plain and Tall by Patricia MacLaclan  
Little House on the Prairie by Laura Ingalls Wilder  
Courage of Sarah Noble by Alice Dalgliesh

This section has been split up in two parts. The first part lists books and authors related to the Oregon Trail theme. The second part of this section takes the book Sarah, Plain and Tall and shows you a sample teaching unit for the novel. The Little House on the Prairie books can also be taught using a literature approach. There is also a short text describing the legend of The Bridge of the Gods as well as the legend of the Ki-use Twins.

**SECTION ONE:  
LINKING UP WITH LITERATURE**

**Native American Books:**

The Legend of the Bluebonnet	by Tomie dePaola
Dancing Tepees: Poems of American Indian Youth	by Virginia Sneve
Buffalo Women	by Paul Goble
The Gift Of the Sacred Dog	by Paul Goble
Beyond the Ridge	by Paul Goble
Death of the Iron Horse	by Paul Goble
Star Boy	by Paul Goble
Iktomi and the Ducks	by Paul Goble
Dream Wolf	by Paul Goble
Iktomi and the Berries	by Paul Goble
Her Seven Brothers	by Paul Goble
Iktomi and the Boulder	by Paul Goble
The Girl Who Loved Wild Horses	by Paul Goble
The Mud Pony	by Caron Lee Cohen
Indian Chiefs	by Russell Freedman
Bears Heart	by Burton Supree/Ann Ross
The Story of Jumping Mouse	by John Steptoe
Legend Of Indian Paintbrush	by Tomie dePaola
Sweetgrass	by Jan Hudson
Where the Buffaloes Begin	by Olaf Baker
Sing Down the Moon	by Scott O'Dell
Jimmy Yellow Hawk	by Virginia Sneve
High Elks Treasure	by Virginia Sneve
Happily May I Walk	by Arlene Hirshfelder
The Goat in the Rug	by Charles Blood & M. Link
Keepers of the Earth	by Michael Caduto

### Frontier & Pioneer Life:

Pioneering on the Plain	by Carol Rogers
Wagons Over Mountains	by Carol Rogers
I Can Read About Pioneers	by C. J. Naden
Trappers and Traders	Rourke Corporation
The Josephina Story Quilt	Eleanor Coerr
Wagons West-Off to Oregon	by Dick Smolinski
The Golly Sisters Go West	Troll Associates
Frontier Dream-Life on the Plains	by Catherine Chambers
Over the Mormon Trail	by Helen Jones
Pioneers	by Dennis Fradin
Early Travel	Crabtree Pub. Co
If You Traveled West in a Covered Wagon	by Ellen Levine
Little House on the Prairie	by Laura Wilder
American Tall Tales	by Adrien Stoutenburg
The Pioneers Go West	by George Stewart
The Sign of the Beaver	by Elisabeth Speare
Meet at the Falls-The Story of Pioneers	by Ruth Reuther
West Against the Wind	by Liza Murrow
Young Mister Meeker & His Exciting Trip to Oregon	by Miriam Mason
Patty Reed's Doll-Story of the Donner Party	by Rachel Laurgaard
The Cabin Faced West	by Jean Fritz
On the Banks of Plum Creek	Harper Children's Books
The Story of the Homestead Act	by Conrad Stein
Settlers in the American West	by Margaret Killingray
Women of the Old West	by Judith Alter
Growing up in the Old West	by Judith Alter
Winter Danger	Harcourt

Pioneering on the Plain	by Carol Rogers
Jane Long-Frontier Woman	by Ann Crawford
Pioneers	by John Artman
Veins of Silver & Gold	by Robert Perez
Food for the Settler	Crabtree Pub

**Immigration:**

Hector Lives in the United States Now	by Joan Hewett
How Many Days To America	by Eve Bunting
Angel Child, Dragon Child	by Michelle Surat
The Wooden Doll	by Susan Bonners
The Wednesday Surprise	by Eve Bunting
The Keeping Quilt	by Patricia Polacco
My Grandmother's Journey	by John Cech
My Grandmother's Stories	by Adele Geras
From Anna	by Jean Little
Tales From Gold Mountain	by Paul Yee
Children of the River	by Linda Crew
The Star Fisher	by Laurence Yep
Dragon Wings	by Laurence Yep

## SECTION TWO: SARAH, PLAIN AND TALL

The book Sarah, Plain and Tall is an excellent book for grades 3-6. Even though the book is fairly easy to read and rather short, it lends itself very well to the teaching of basic reading skills and concepts. There is an abundance of teacher related material available to select from as a supplement to this book. The ideas suggested below are just a start. Build and add to these ideas and expand the book to include various art projects such as murals or sketches of scenes. The mini-lessons below are set up so that as students finish the assigned reading for that day, they can then work on a project related to their reading. It is suggested that students have a "Sarah, Plain and Tall" notebook to write or record their lessons and projects.

- Step 1-- The object of the first mini-lesson is to introduce students to the concept of imagery and mental pictures. This is done prior to the reading of the first chapter. List several generic word on the board such as home, cat, school, etc. Also have the five senses (sight, smell, taste, hear, touch) on the board as well. Have the kids brainstorm how the generic words such as cat create or form mental images based on the five senses. For the second portion of this lesson, write key words such as pioneer, sea, etc. (words related to the book) on the board. Have students brainstorm these words looking for mental pictures. They can then share their thoughts with the entire class. They should do this brainstorming in groups of two to three.
- Step 2-- Before reading the first two chapters discuss different forms of letter writing with the students. Remind them that information read in a letter is turned into mental pictures within their minds. After reading the first two chapters have students pretend that they are one character in the book (Sarah, Papa, Caleb, Anna). They will take that character (example; Anna) and write to another character (example; Sarah). When done they can share their letter with the class. Their letter should relate to the book so they will have to have a fairly good understanding of the first two chapters to correctly complete the letter.
- Step 3-- The object is for students to understand the concept of "point of view." Before reading any additional chapters, remind students about letter writing and how point of view is related to this. Whomever is doing the writing in the letter has an established perspective or point of view. Have students read the next two chapters. When finished they will write down the 4 main characters on a sheet of paper and write how each character feels in the story from their point of view.

An example of some questions you might have students think about are:

1. Does Anna feel sad because Papa wants a new wife?
2. How does Sarah feel about leaving her home and coming out west?
3. Does Papa have any feelings towards his deceased wife?

4. Does Caleb have feelings about having a new mother?

Step 4-- The object is to establish and understand the difference between main characters and supporting characters. Pick a book which can be read to the class in a few minutes. Discuss with the class who might be the main character and supporting characters in the book. Now relate this concept to Sarah, Plain & Tall. Write on the board the characters and how they interact with each other. Instruct them to read the next two chapters. When finished with their reading, have the students write down the character names and determine if they are main or supporting characters. They should give support for their answers.

Step 5-- The object is for students to understand the motives behind doing things. Talk about motives and why people do things. Relate motives to kids' lives and why they behave certain ways or play certain games. Then talk about Papa's motives for placing an ad in the paper. Discuss and have them read the next two chapters. When done, they will take each character and brainstorm their motives for behaving the way they do in the book. Examples might be:

1. Why did Sarah agree to come?
2. Why does Anna feel reserved and shy around Sarah?
3. Why does Papa act so stubborn?
4. Why does Caleb ask so many questions about Mama?

When they are done, have them discuss and share these motives with the class.

Step 6-- Have students read the last two chapters. When finished they can write an ending to the book. Share with the class.

Step 7-- Watch the movie, "Sarah, Plain & Tall" and afterwards have students think on how the movie differed from the book. Discuss.

You can also talk about the format of the book. For instance, have students take the book and record in their journals the following:

Title  
Author  
Copyright Date  
Illustrator  
Publisher  
Dedication



Students should become very familiar with the layout of books as well. Review with the class the importance of having a good beginning, middle, and ending to each story. When finished with "Sarah, Plain and Tall" have the class brainstorm the beginning, middle, and ending. Look for patterns in other books and see if all books are the same. If not, how do they differ?

### **LEGEND OF THE BRIDGE OF THE GODS**

Where the Cascades of the Columbia are now, there once was a huge arch under which the river flowed. Over the river was a broad and level roadway over which the people of the south and the people of the north rode back and forth. This was not too long ago--perhaps five or six, old, old squaws ago.

This bridge was known by the Indians as the Bridge of Tomaniwuas. At this time the country to the south and the north was a fertile plain. There did not exist the peaks of St. Helens, Mt. Hood, and Mt. Adams. Midway in the bridge a fire was kept burning by an old witch woman. Her hair was scraggly, her teeth were yellow and cracked, and she had the scolding, cackling voice of all witch women. Her name was Loowit. Indians would try to steal the fire. She would not even let them come near to get warm, and even though she felt sorry for them, she scolded and scourged them so they would not come too near.

Finally she could no longer stand it and she asked Tomaniwuas if she might give the fire to the people. He consented and she gave the people the fire so they might be warm and eat cooked food.

Now the people stopped and talked to Loowit as they passed back and forth. There were two great chiefs living at this time---Wyeast, chief of the southern Indians, and Klickitat, chief of the northern Indians. The chiefs were friends and often met on the bridge. Loowit thought they were handsome.

One night when Tomaniwuis came to talk to her, she asked that he might grant one wish to her. He said that because she was very faithful, he would grant her just one wish. She asked that she might be young and beautiful. Tomaniwuis sighed because he was afraid that there would be trouble, but he granted her wish.

The next day, tales of Loowit's new beauty spread far and near on the two sides of the river. Many young braves came to admire her, and she no longer had to gather the wood as the young men brought it to her. Above all the young men, Loowit liked Wyeast and Klickitat the best. Both of the great chiefs fell in love with her too, but she could not choose which one she liked the best. Before this, the people of the north and south had been friendly, but now with the two chiefs rivals for the hand of Loowit, the two nations became rivals too. The chiefs no longer stopped to talk on the bridge. The people no longer went back and forth in peace. Wars broke out and people were killed. Tomaniwuis was angry with Loowit and one night he came down to the bridge. Loowit begged him not to change her back into an old crone.

"No," said Tomaniwuis, "I will kill you."

"No," cried Loowit, "What will Wyeast and Klickitat do without me?"

"I will destroy them, too," answered Tomaniwuis. "If they were really good chiefs, they would not let their people go to war about just a woman."

Tomaniwuis killed them both and the two great chiefs went without a murmur of fear. Then Tomaniwuis warned the people on the north and the south to stay a long way from the bridge as he would destroy it so that ever after the tribes would be separated.

That night the thunder roared and the lightning flashed. The earth trembled for miles around. In the center of the arch, a crack appeared. Another appeared six yards from it and a great section of the bridge fell into the river. With it went the fire which Loowit had kept burning until her death. The next morning the fire was no more and in the place of the bridge, the water tumbled over great rocks that had fallen down.

Tomaniwuis did not want to bury the lovely Loowit and her two braves, so he turned them into beautiful mountains where all could see their beauty. Loowit became Mt. St. Helens on the north side with the northern chief, Klickitat, becoming Mt. Adams, beside her. On the south side loomed the southern chief, Wyeast, as he turned into the shining Mt. Hood. These peaks still stand today.

This is just one Northwest Indian legend. In fact, there is more than one version of this legend with all of them being correct depending on which tribe's version you are reading. Some literature which pertains to Indian Legends of the Northwest are:

#### Indian Legends of the Northwest

GRANDMOTHER STORIES OF THE NORTHWEST	By Nashone	Sierra Oaks Publishing Co.
COYOTE WAS GOING THERE	Jarold Ramsey	University of Washington Press

#### LEGEND OF THE KI-USE GIRLS

According to the Walla Walla Indians' tradition, the supernatural animal or the animal which has "medicine powers" is the wolf. Other Indian tribes attribute these powers to various animals such as the coyote, whale, eagle etc. The Walla Walla Indians were located in the southeastern portion of Washington, and the Ki-Use Girls or Twins is a legend about two extraordinary rocks on the Columbia River.

The wolf, the great medicine man, was walking home one day when he came across three beautiful Ki-use (Cayuse) girls. He fell desperately in love with them. The wolf watched as they carried stones into the river. They were trying to make an artificial cascade or rapid, to catch the salmon that would leap over it. The wolf secretly watched their operations throughout the rest of the day. But during the night, the wolf would come and destroy what they had built. He did this for successive evenings. On the fourth morning, he saw the girls weeping on the bank, and

inquired what was the matter. They told him they were starving, as they could get no fish since they have no dam. The wolf then proposed to build a dam for them, if they would become his wives. The Ki-use girls consented or sooner die from the lack of food. The wolf built a dam using stones which stretched from one end of the Columbia to the other.

For a long time he lived happily with the three sisters (a custom very frequent among the Indians, who marry as many sisters in a family as they possibly can); but at a length the wolf became jealous of his wives, and, by his medicine powers, changed two of them into basalt pillars, on the south side of the river. He then changed himself into a large rock, somewhat similar to them, on the north side, so that he might watch them for ever afterwards. But what happened to the third sister? Did you not notice a cavern between the rocks where the river now flows? That is all that remains of her.

*\*\*\*This legend was written down by the artist, Paul Kane, as he made his way throughout the northwest in the 1840's. This was how the Indians of the Walla Walla and Cayuse tribes explained the rocks bordering the Columbia River near the present Walulla Junction.*

# SPELLING

## SAMPLE SPELLING WORDS FOR CHALLENGE

abandon	epidemic	millers	sawyers
adobe	fellow	millpond	settler
agriculture	Flathead	mission	settlers
Alice Clarissa	Fort Walla Walla	missionary	sheep
ammunition	frontiersman	moccasin	Shoshoni
axle	fur trapper	Modoc	Snake
bastion	geese	molasses	spinning
beads	Great Grave	Narcissa	Spalding
billowing	grist mill	Nez Perce	stockade
bitter root	hearthstones	orchard	tarpaulin
Blackfeet	heirlooms	Oregon	tepee
blacksmith	hub bearing	Oregon Fever	tomahawk
board	Hudson's Bay	oxen	traders
bunch grass	Independence	papoose	treaty
bushel	Indian	Paiute	trough
camas	irrigation	patriotic	tule
canvas	journals	plough	typhoid
Cayuse	Klickitat	pioneer	Umatilla
Chinook	livestock	prairie	wagon
cholera	lodge	Presbyterian	wagon bows
churn	Marcus	prospector	wagon box
cornmeal	massacre	religion	wagon tongues
cradleboard	measles	rye grass	Waiilatpu
deserted	medicine	schooner	Whitman
Deshute	medicine man	rawhide	wool
Dutch Oven	memorial	Sager	yoke
dysentery	Memorial Shaft	salmon	
emigrant	migration	sapling	

Some other projects that you can do with spelling could include the following:

1. Word Searches
2. Crossword Puzzles
3. Matching Exercise

*\*\*An excellent program to generate word searches and crossword puzzles is contained within the software titled PUZZLES AND POSTERS. This program is available on both IBM and APPLE computer systems.*

4. Spelling Bees
5. Syllabication

## WEIRD SPELLING

As trading increased between the fur trappers and the Indians, a common language was needed. This language is a combination of French, English, and several Indian languages. While this is the language used for trading, the real Chinook language has long since disappeared.

1. baby-----tenas
2. beaver-----eena
3. canoe-----canim
4. deer-----mowitsh
5. dog-----kamooks
6. duck-----Kweh Kweh
7. eagle-----chak chak
8. elk-----moolock
9. family-----tillicums
10. fire-----piah
11. fireplace-----kah piah
12. grandfather-----papa kaka papa
13. grandmother-----mama kaka mama
14. How are you?-----Klahowya
15. love-----tikegh
16. potato-----wappatoo
17. thank you-----mahasie
18. parents-----papa pe mama
19. pants-----sakoleks
20. students-----tenas kopa school

You may want to take these words and go over them with your class. How did they arrive at common ground? Discuss possibilities. Take several different languages such as English, Spanish and Japanese. Have students take several words and try to combine them into a common language. Possibly use vocabulary words.

# GEOLOGY

As the pioneers traveled the Oregon trail they came across various landmarks which they used to identify their position along the way. Examples would be Chimney Rock (Nebraska) and Independence Rock (Wyoming). The Cayuse Indians also had a landmark rock that came from an Indian Legend. It is located at Wallula Junction and is known as the "Ki-Use Girls." Smaller rocks were used as fishing net weights.

Integrate geology into your curriculum by doing some of the following activities:

1. Review the three basic types of rocks: basalt, igneous and metamorphic. Have examples of each rock type for students to handle and examine. Discuss the differences of these three rock types and identify the rocks which the pioneers saw or used. Various uses of different rocks could be discussed and researched. Groups can review and research types of rocks and write mini-reports.
2. Have the kids simulate Independence Rock by writing their names on a piece of butcher paper and including their own personal messages.
3. Talk about hardness levels of different rocks. (Example-Limestone is a very "soft" rock, while granites and basalt are "harder" rocks.)
4. Have students bring in their own rock samples and match these with class samples. Students can also do this matching activity blindfolded and use only their sense of feel (hands only) to match up rocks by examining rock surfaces.
5. Have the students write about various uses of rocks (in the past and present). How did the pioneers and Indians use rocks? How do we use rocks today? Have uses for rocks changed through time? What materials do we use today instead of rocks? Why has the use of rocks increased or decreased over time?
6. Retell the Indian story of the "Ki-Use Girls" and have the students develop and write their own version of this legend. (The Cayuse Indians, Ruby & Brown, pgs. 75-76, or see Oregon Trail Teacher's Guide -- Language Arts.)
7. Study the continental divide and how the rivers will flow downward and towards the ocean. Have students locate the Oregon trail on a map as well as the major rivers. In which direction do the rivers flow? Why?

# SOILS

## Initial Questions to ask Students:

1. Why did the pioneers settle in the Willamette Valley?
2. Why did they not establish the settlements closer to the Columbia River where access to supplies would be easier? (Remember, good soil was important to farming.)

## Possible Activities:

1. Review different types of soil such as clay, sandy and rocky.
2. Review difference in topsoil, subsoil and bedrock. (It helps to have samples of each soil type as well as a magnifying glass.)
3. During the spring, identify and research the crops that Whitman grew at the mission site. (These should be corn, wheat, squash, potatoes, tomatoes, peas, melons and other basic vegetables.) In groups, have the students plant these vegetables in a different soil type. Have students predict what will grow the best and in what type of soil. Verify whether predictions were accurate or not--discuss reasons for accurate or inaccurate predictions.
4. If possible, make adobe bricks using materials in the following combinations:  
  
clay soil and straw  
sandy soil and straw  
sandy soil only  
clay soil only

Predict which "adobe brick" will hold up best to weather and construct.

## Adobe Brick Construction:

1. It will be necessary to make a mold to form the bricks. Whitman used a mold which measured 20" x 10" x 5". A mold can easily be constructed using pre-cut lumber.
2. Adobe is made best from clay soil mixed with straw. Mix the soil with water until it becomes quite thick.



3. Once the mixture has thickened, place it into the wooden mold.
4. Let it bake in sun for one to two hours (depending on weather and thickness of clay).
5. Once the clay has hardened, carefully take it out of the mold and lay this "brick" on end for an additional ten days before building.

*\*\* An alternative method would be to scale down the adobe bricks to a more manageable classroom size. (Approximately 2" x 4") Additionally, other items could easily be used as molds rather than having to construct them from scratch.*

For example:

- small milk cartons
- plastic blocks
- cardboard shoe boxes
- Tupperware containers

From these smaller molds, smaller bricks would be produced, and it would be feasible to construct semi-scaled models of the mission buildings.

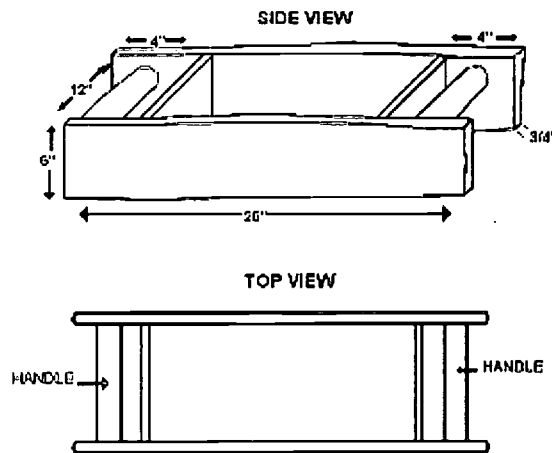

# Health

Compare diseases of yesterday and today. Mini-reports on various diseases would be appropriate. Reports could include causes of different diseases, numbers of people afflicted by various diseases, whether or not a disease was/is contagious, various symptoms, and available treatments or cures.

## **Diseases of Yesterday (During 1800's to early 1900's)**

Dysentery

Measles

Influenza

Cholera

Scurvy

High Infant Mortality

Low Life Expectancy

## **Diseases of Today**

Cancer

Heart Disease

Drug Abuse

Alcoholism

Obesity

High Blood Pressure

Aids/Sexually Transmitted Diseases

# SEASONS

The early pioneers left St. Louis and Independence in early to late spring. They traveled the Oregon Trail and would arrive in Oregon in late fall.

- Why did they leave St. Louis when they did?
- Why not later when the water runoff in the rivers was not so high (as it would be later in the summer?)
- Have the students look into average rainfall and snowfall (precipitation) throughout a year in various locations in the United States.
- Which states receive more rainfall than other states?
- Which states receive less rainfall than others?
- What are some of the reasons different areas receive varying levels of rainfall (or precipitation?)
- Following the route of the Oregon Trail, determine and discuss various hazards or benefits of traveling during different times of the year.

## Classroom Activities:

1. Talk about the relation of the sun to the earth. Review the tilt of the earth and its axis. Why do we have four seasons?
2. The Indians had a yearly cycle where in particular months they would perform certain activities. In the Cayuse section of this teacher's guide, there is a cycle showing what they did at various times of the year. Review these activities and discuss why they had this cycle. Did the pioneers have a seasonal cycle? Do we have a similar cycle today? Why or why not?
3. The Indians had no written language. Therefore, poetry as we know it today did not exist. Instead, the Indians used songs as a form of expression. Nature was extremely important to the Indians and the weather/seasons cycle dictated when certain songs were sung or new songs were created. Have students listen to traditional native songs (not to understand the language, but to listen carefully for the way the songs were sung--paying attention to the beat, rhythm, instruments, voices, etc...) The students then could perform their own songs based on nature/seasons, or other areas of personal interest.
4. To use in conjunction with the above: Have students look for modern day songs

that have a nature/season theme. Compare their creations with the ones they found and discuss the differences.

5. Have the students work in groups of 2-3. With butcher paper, create a mural depicting a particular activity or activities occurring during a selected season. Make sure that all the seasons are being represented and upon completion, all the murals could be combined and displayed for discussion.

## AGRICULTURE

1. Set up a touch table that has grains, fruits, and vegetables (wheat, barley, peas, corn, beans, berries, and squash). Present the whole plant as well as its seeds. Using magnifying glasses, have students observe, touch, and record their individual observations.
2. As a class project, make whole wheat bread. Students can work in small groups of two or three, and then make their own loaves of bread.
3. Take a cup of oatmeal or corn meal. Slice a potato in half and place inside your cup of meal. Meal worms will eventually become evident. Have students observe and record their observations. They can also graph individual days and the results. (For example, the total numbers of meal worms they count each day.)
4. Have students grow wildflowers much like the pioneers did when they reached the Oregon country. Study different kinds of flowers and describe the growth of these flowers. How do they spread (or reproduce?) What type of seeds do they have? What do they look like?
5. Pioneers encountered many different types of trees along the trail. Trees were very important since the pioneers needed firewood and eventually, shelter. Logs were dragged behind wagons when travelers needed to slow down their speed when negotiating steep hills or grades. Logs were also attached to the wagons when floating across streams, because logs would float and provide buoyancy.

On construction paper, trace the outline of leaves found in your area. Take your class for a nature walk and have students identify the trees by comparing the leaves. Attached you will find several basic leaf outlines. You will have to add to these, but this will give you a good idea of what to look for and how to create your own leaf outlines. Cottonwoods and willow trees are typically found along streams and rivers, so these types of trees were well known to the pioneers.

6. Explain why it was necessary for the pioneers to take along a supply of dried fruit (to prevent scurvy). As an activity, dry some fruits and vegetables and share these with the class. Can they determine what the different fruits are? Do they taste the

same as fresh fruit? Relate the pioneers on the Oregon Trail to the pioneers of space (astronauts) and explain how dried fruit was and is important to both while on their long journeys.

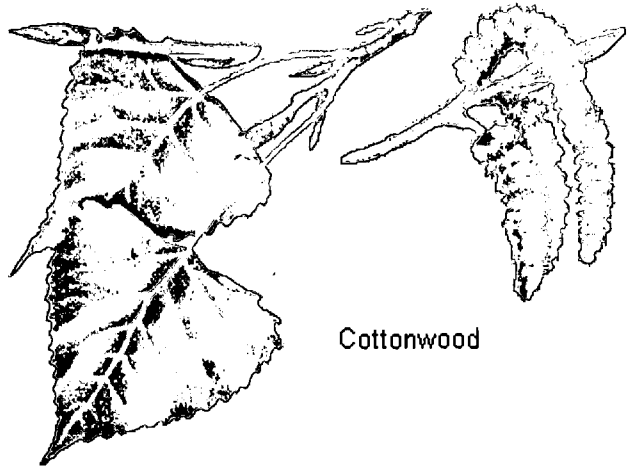

Cottonwood



American Elm

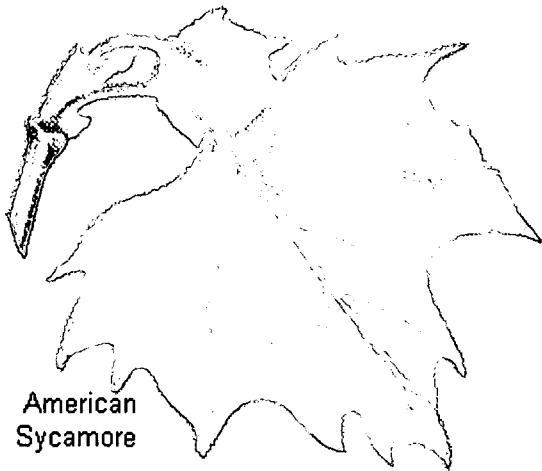

American Sycamore

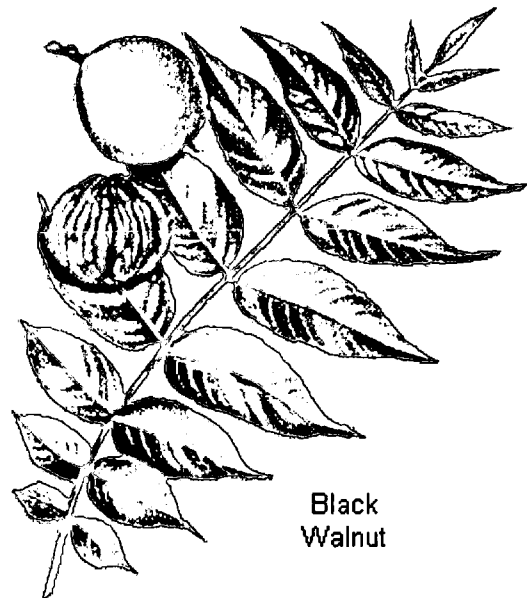

Black Walnut

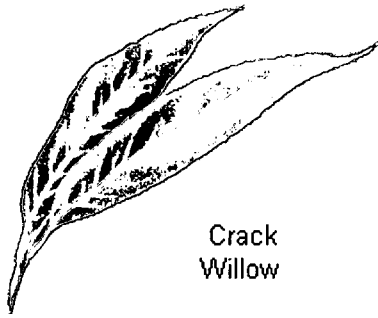

Crack Willow

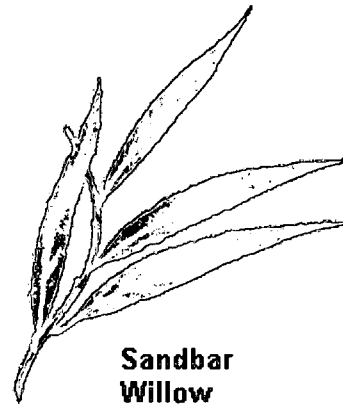

Sandbar Willow

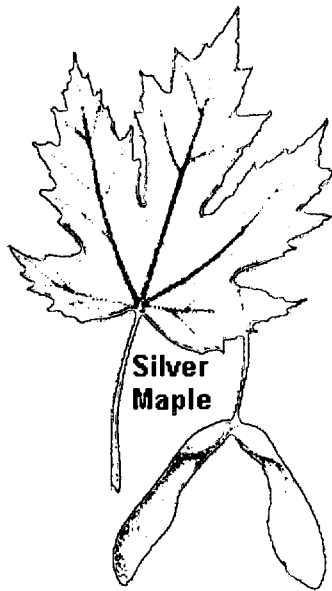

Silver Maple



Staghorn Sumac

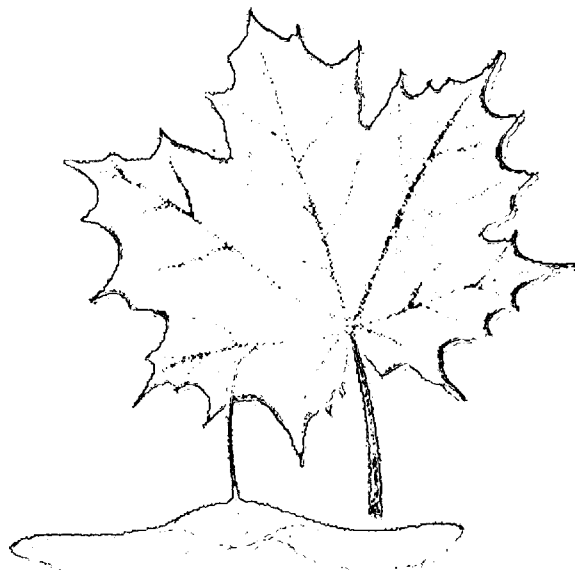

Norway Maple

## **WILDLIFE BIOLOGY (Tracking)**

One important skill for the pioneer to possess along the Oregon Trail was to have the ability to trail or track animals. To become truly adept at this skill required years of practice. Obviously, this skill was needed because food supplies began to run low or become completely exhausted as the emigrants got closer to the Oregon country. Below are a few activities which highlight this skill.

1. How can you tell if an animal is running, trotting, or walking? The attached page shows an example of horse tracks. Run off copies of this page and have the students determine these differences between running, trotting, and walking. Note how the detail of the track becomes more obscure as the pace of the animal increases. Also, the length of stride increases as well. For an activity, have students go outside and make tracks of their own. Other students can then look at the tracks and guess who made them (possibly, by looking at tread) and the pace, (Running, trotting, or walking).
2. Match up the animal with the animal track. The attached pages show a list of animals and the corresponding tracks they make. Copy, cut out, and laminate these onto colored construction paper and hand out to groups of students. Have them match the name of the animal to the corresponding track.
3. Develop a "Touch" center using different animal pelts or fur. Attach the sample animal pelts or fur to a piece of tagboard. Have students try to guess the animal from which it came from. They can keep a journal of this and record their observations. How do the pelts differ? In what ways are they alike?

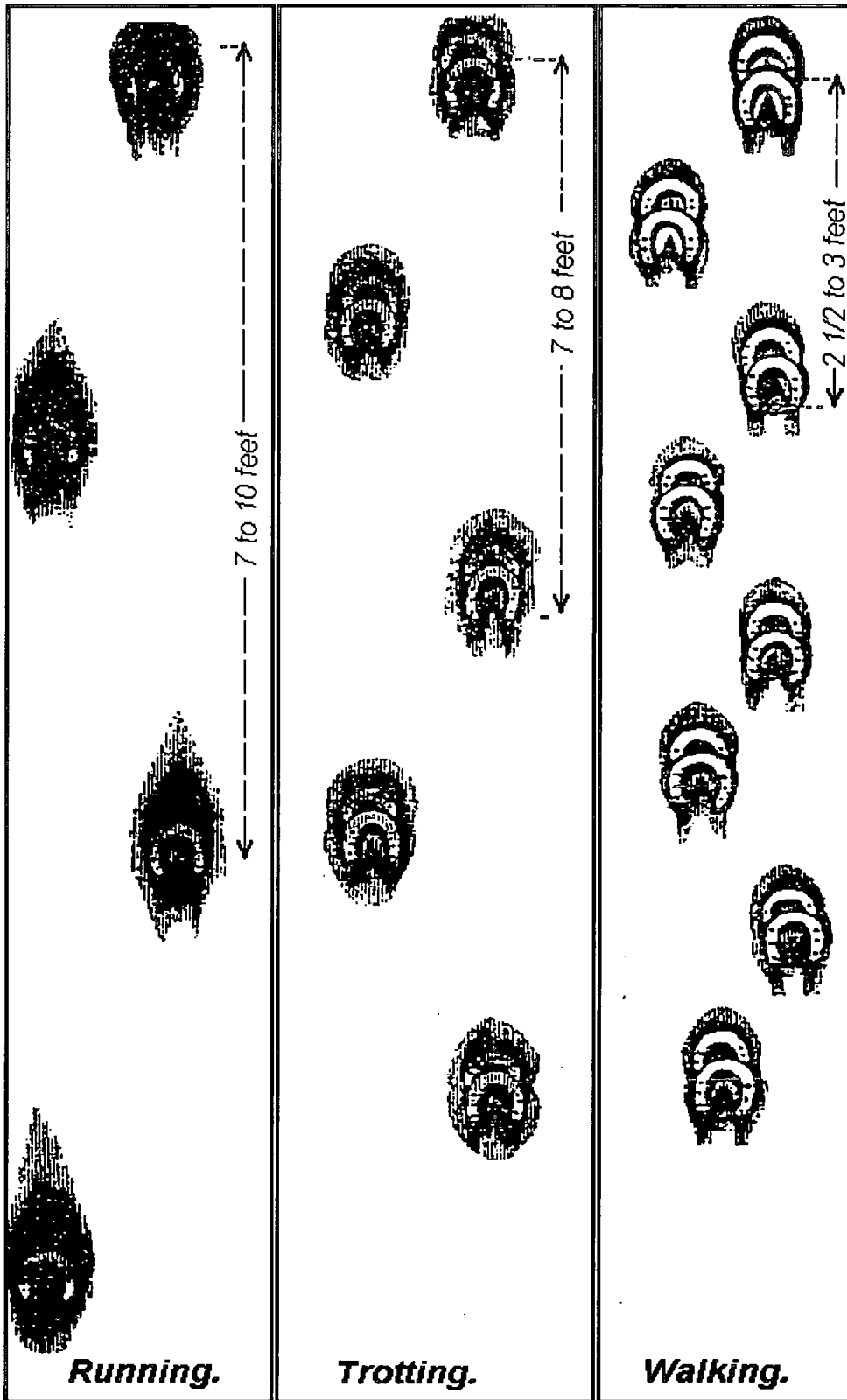

**HORSE-TRACKS AT ORDINARY SPEED**



# Common Animal Tracks

Use this with the page entitled "Common Tracks of Animals". The numbers next to the animal's name correspond to the number next to the animal's track.

- |                             |                       |
|-----------------------------|-----------------------|
| 1. Moose                    | 2. Elk                |
| 3. Mountain Goat            | 4. Bighorn Sheep      |
| 5. Deer                     | 6. Pronghorn Antelope |
| 7. Horse                    | 8. Domestic Cat       |
| 9. Large Dog or Wolf        | 10. Coyote            |
| 11. Red Fox                 | 12. Mountain Lion     |
| 13. Badger                  | 14. Striped Skunk     |
| 15. Long Tail Weasel        | 16. Beaver            |
| 17. Muskrat                 | 18. Rock Chuck        |
| 19. Pine Squirrel           | 20. Deer Mouse        |
| 21. Meadow Vole             | 22. Shrew             |
| 23. Black Tailed Jackrabbit | 24. Cottontail Rabbit |
| 25. Raccoon                 |                       |

# COMMON TRACKS OF ANIMALS

## MAMMALS

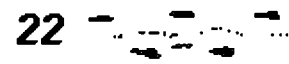
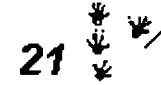
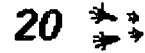
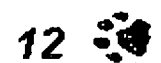
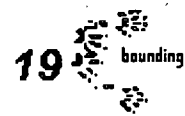
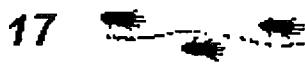
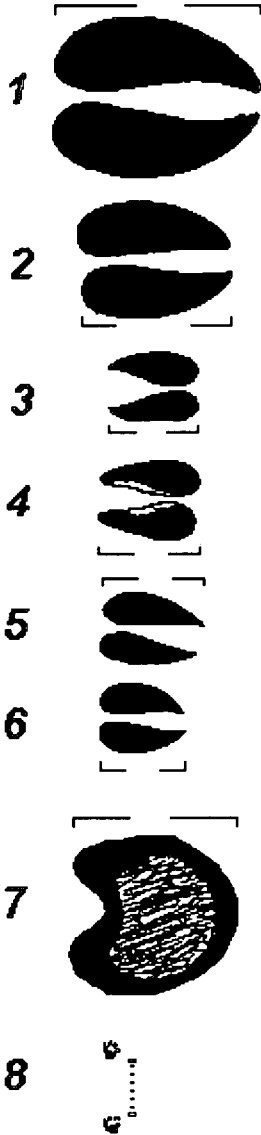

# OREGON TRAIL TEACHER'S GUIDE

## SECTION NINE - MATH ACTIVITIES

Math can easily be incorporated into the Oregon Trail unit. One form of math was used daily by pioneers to measure distance traveled as well as estimating distances between two points.

1. As the pioneers traveled, they would measure distances by the revolution of their wagon wheels. If you have a wagon wheel available, have students measure distances (by counting revolutions of the wagon wheel) between various points. Students can then compare this distance with that of more standard measurement such as tape measures, meter or yard sticks, rulers, etc. Which form of measuring distance is the easiest to do?
  
2. The prices of supplies differed from one trading post to another. Have the students figure out these differences, and using shopping advertisements of today, have them compare the prices and dollars spent.

	Fort Hall	Fort Boise	Whitman Mission	The Dalles
Flour	.20 per lb	.20 per lb.	.05 per lb	.18 per lb.
Beef	-----	.20 per lb	.07 per lb	.25 per lb.
Sugar	.50 per lb	.40 per lb.	.20 per lb	.20 per lb.
Bacon			-----	.50 per lb.

3. The pioneers would have to estimate the distance across a river in order to ford it safely. Using Jack's math, (attached) have students estimate the distance between two points in the school yard. (Jack's Math-Pacing Method.)
  
4. The Oregon Trail had many ups and downs. Using the attached sheet showing the altitude along the trail, have the students graph the altitude along the key landmarks. They can also graph your cities elevation as well.
  
5. Families loaded only things they needed in order to survive the hard trail. Below is a partial list of some items. Have students look up the cost of these items (catalogs or advertisements) and total up the amount.

Ax, rope, shovel, saw, 1 pair of shoes per each person, 2 pairs of boots per each person, 3 iron pots, skillet, 3 knives, tin dishes, spoons, 2 sets of clothing per each person, flour/600 lbs., sugar/75 lbs., salt/25 lbs., rice/30 lbs., meat/300 lbs., small camp stove, tent, and 1 blanket per person.

6. Practice regrouping with subtraction by finding the differences between today's date and important dates in Oregon Trail history.
7. Wheat was an extremely important crop for early pioneers. Establish a Guessing Jar by filling a jar with Wheat Chex and have students estimate the number of Chex. Graph and share equally among class.
8. As you read *Little House on the Prairie*, have students find the distance in miles from her old home in Wisconsin to her new home in Kansas.
9. Since so many hispanic students travel to Texas during the Winter months, find the distance from your town to Texas and graph it. Compare this with the mileage traveled on the Oregon Trail. What is the difference?
10. If you are able to visit the Whitman Mission National Historic Site, do the following. The perimeter of the locations of the mission buildings are outlined with cinder blocks at Whitman Mission. Have the students measure the distance around each building. Various forms of measuring could be used. Students could work in groups. Dimensions of each building could be recorded and compared. An interesting activity would be to compare the sizes of mission buildings with sizes of present-day homes!
11. With measuring tapes or strings, have the students measure the circumference of trees at the site. Are circumferences of one type of tree noticeably different from other types of trees? Why do you think they are different?
12. Determining age of trees. Obtain core samples from the local Forest Service Office. (These are free!) By counting rings, core samples clearly reveal the age of trees. By comparing various core samples with similar trees at your school or town, you can then estimate the age of trees. A second way to determine the age of trees is to examine a cross-section from a log. Students add up the rings to determine the age of the tree.
13. With the tree-ring samples, have students look up specific dates in almanacs and determine what significant events occurred on various dates.
14. The following list is a breakdown of the cost (1849 prices, St Louis Missouri) of certain supplies that pioneers might purchase before leaving on the Oregon Trail. Have students find the difference and compare these prices with to those of today. How much more expensive are they now?

	1849 Prices	Today's Prices
coffee	.08 per lb.	
tea	.55 per lb.	
bacon	.05 per lb.	
flour	.02 per lb	
sugar	.04 per lb.	
rice	.05 per lb	
dried fruit	.06 per lb	
salt	.06 per lb.	
soap	.11 per lb.	
candles	.11 per lb	
lard	.05 per lb.	
tent	\$5.00 ea	

You can also have the students compare these prices to those found along the Oregon Trail. Note how the price usually increases as they get further out into the Oregon Country. Some sample questions might be:

Why did the cost of supplies increase as they traveled further West?

Why were the prices at Whitman Mission cheaper than some of the posts and forts?

What was lard used for?

Why did they purchase dried fruit?

What was the importance of dried fruit?

- The following is a list showing the approximate number of people by year whose destination was either Oregon or Utah/California. (Note the year 1849 as it shows the impact of the California Gold Rush and the years just prior to that show the beginning of the Mormon migrations). Have students utilize and practice place value as they find differences between the years. They can also review basic addition and subtraction skills.

Year	Oregon	Utah/California
1840	13	0
1841	24	34
1842	125	0
1843	875	38
1844	1,475	53
1845	2,500	260
1846	1,200	1,500
1847	4,000	2,650
1848	1,300	2,800
1849	450	26,500
1850	6,000	46,500
1851	3,600	2,600
1852	10,000	60,000
1853	7,500	28,000
1854	6,000	15,167
1855	500	6,184
1856	1,000	10,200
1857	1,500	5,300
1858	1,500	6,150
1859	2,000	18,431

16. Obtain some old currency and have kids feel and observe the difference between today's money and that of yesterday. How do they differ? Have students count out change using the old currency.
17. Measure the circumference of a wagon wheel. Have students determine how many revolutions of a wheel it would take to cover approximately one mile of ground.

# JACK'S MATH

## Measuring Your Pace

1. Mark off 50 feet on the ground.
2. Starting with your toes on a starting line, pace the distance 10 times.
3. Divide the total paces by ten.  
125 paces  
10 times = 12.5 paces (average)  
  
125 paces--**divided by**--10 times--**equals**--12.5 paces (average)
4. Divide 50 feet by average paces. This is your length of pace.  
50 feet  
12.5 paces = 4 foot pace  
  
50 feet--**divided by**--12.5 paces--**equals**--4 foot pace

## Personal Measurements

Name \_\_\_\_\_ Date \_\_\_\_\_

Address \_\_\_\_\_ Age \_\_\_\_\_

My height is \_\_\_\_\_ feet, \_\_\_\_\_ inches

My eyes are \_\_\_\_\_ feet, \_\_\_\_\_ inches above the ground.

My reach across, from tip of one outstretched hand to the tip of the other, is \_\_\_\_\_ feet,  
\_\_\_\_\_ inches.

The length of my forearm, from tip of little finger to elbow, is \_\_\_\_\_ feet, \_\_\_\_\_ inches.

My hand span, from thumb to little finger, is \_\_\_\_\_ inches.

The breadth of my thumb is \_\_\_\_\_ inches.

The length of my index finger is \_\_\_\_\_ inches.

The length of my foot is \_\_\_\_\_ inches.

The length of my pace is \_\_\_\_\_ feet.

Distance from my \_\_\_\_\_ to \_\_\_\_\_ is exactly one inch.\*\*

Distance from my \_\_\_\_\_ to \_\_\_\_\_ is exactly one foot.

Distance from my \_\_\_\_\_ to \_\_\_\_\_ is exactly one yard.

*\*\*Example: End of thumb to first joint. Must be determined for individual.*

## MEASURING WIDTH

### Indian Method

1. Stand on edge of pond. Place hand on forehead as though you were shading your eyes.
2. Tilt outside edge of palm downward until its edge seems to touch the other side of the pond. Hold hand steady and do not move it!
3. Make a right turn (90 degrees) and note the spot on the ground where the edge of your hand now touches. Mark the spot mentally.
4. Mark the place you are now standing with a stick or a rock.
5. Walk to the spot that you have mentally noted where the edge of your hand touched. Place a stick or rock at that location.
6. Pace off the distances between the two markers. This distance should be approximately the same as the width of the pond.

### Pacing Method

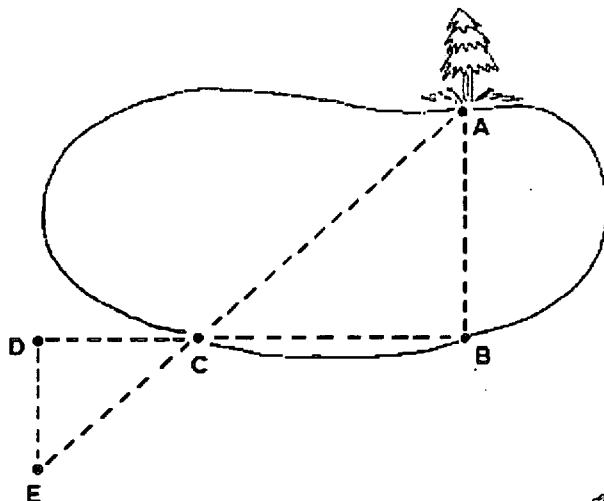

1. Note a landmark (a) on the other side of pond. Place a stick (b) where you are, exactly opposite the landmark.
2. Stand at stick and pace off 100' at a right angle to line (ab). At this point place another stick (c).
3. Continue pacing along this line for half as much distance as before (in this case 50'). Place another stick (d).



4. Make another right angle and walk until you can sight stick © and the landmark (a) in a straight line, then stop. With another stick mark this point (e).
5. Now line (de) is half the distance across the pond. Pace line (de). Multiply line (de) by two. This is the approximate distance across the pond (line ab).

### Compass Method

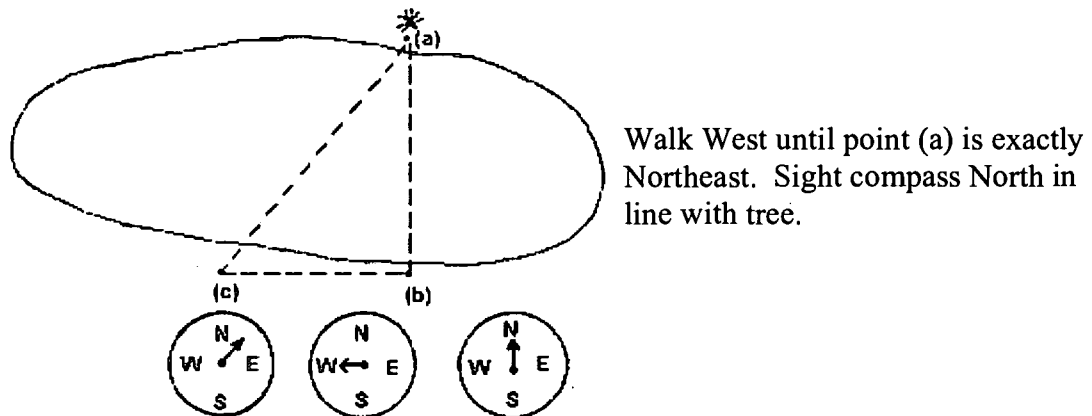

1. Point compass North. Take compass reading across pond on landmark (a). (In example above North is across the pond). Place stick at point (b).
2. Turn (90 degrees) on the compass (in example this is a West). Now walk until the compass is halfway between the reading at point (ab) and the reading on the line you are now proceeding (bc). (In the example this is NE.)
3. At this point (c), line (bc)=line (ab). So pace distance of line (bc) and this is the distance across the pond.

### MEASURING HEIGHT

#### Indian Method

1. Walk away from the tree, bend over and sight its top between your legs. When you can see the top of the tree while in this position, stop.
2. The approximate height of the tree will equal your distance from the tree. In bending over, grasp your knees or your ankle.

#### Stick Methods

1. Mark your height on the tree trunk.

2. Step back several spaces. Hold a stick up before you in an outstretched hand. Sight the height of your mark on the tree and mark this on the stick with your thumbnail.
3. See how many times this height goes up the tree. Multiply the number of times by your height. This is the approximate height of the tree.

### Shadow Method

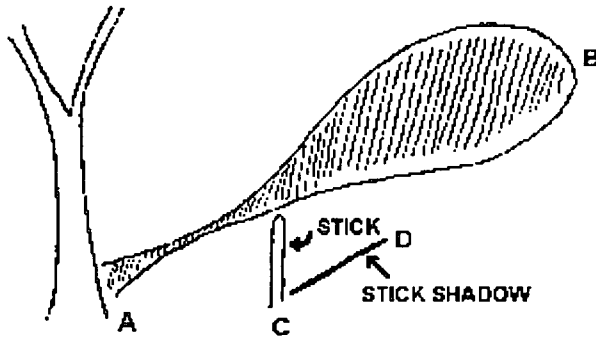

**Formula:** Length of tree shadow (ab) X Height of stick  
 Length of stick shadow (cd) = height of tree

(Length of tree shadow [ab]--divided by--Length of stick shadow [cd]--times  
 --Height of stick--equals--Height of tree).

### MEASURING SLOPE

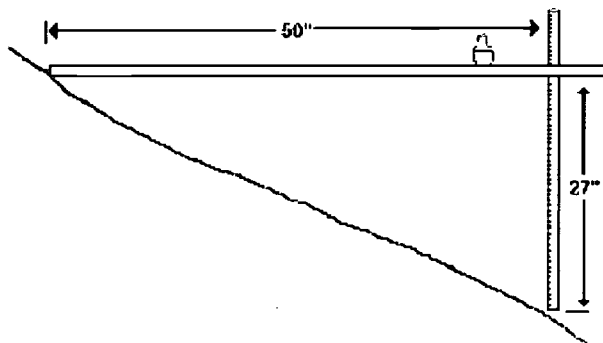

1. Percent of slope is the number of units the land falls or rises in 100 units of horizontal distance.
2. To measure percent of slope use a stick 50" long and a level, or bottle with water and a yardstick.
3. Hold yardstick in upright position. Place 50" stick on slope and raise free end until it is level. Note its distance above the ground.

4. Read this distance in inches and multiply by two to get percent of slope.

*\*\*By knowing slope of land you can discuss what the best use of the land could be (farming, contour farming, pasture, wildlife, etc...) Get land use designations from Soil Conservation office.*

### **MEASURING WATER FLOW**

1. L (length) = feet
2. W (average width) = feet
3. D (average depth) = feet
4. V (total volume) =  $L \times W \times D$  = cubic feet
5. T (time for float to travel L) = second
6. Rate of flow =  $L/T$  = ft. per second
7. Discharge =  $V/T$  = cubic feet per second

### **MEASURING AREA BY PACING**

1. By pacing, find the perimeter of each house.
2. How do they compare? Which would have the most living space?

### **Blacksmith Shop**

1. By pacing, find the square footage of the blacksmith shop.
2. Find square footage of the left hand room.
3. Eight people lived in this room. How many square feet did each person have to live in?

### **MEASURING CIRCUMFERENCE, DIAMETER, VOLUME AND BOARD FEET OF A TREE**

1. Circumference: Use a tape measure. Measure around the tree at breast height.
2. Diameter: On the back of your tape measure, mark a line 3.14 inches from end of tape. Put a 1" mark there. From that mark, make another mark 3.14 inches farther down and place a 2" mark there. Continue doing this to the end of the tape. Each 3.14 mark represents one inch in tree diameter.

3. Volume: Volume of a cone equals  $1.047 \times \text{radius squared} \times \text{height}$  or  $\pi \div 3 \times \text{radius squared} \times \text{height}$
4. Board feet: One board is a piece of lumber 1 inch thick, 12 inches wide and 12 inches long. This equals to 144 cubic inches. To find the total board feet in a tree, you divide volume in inches by 144 cubic inches.

Volume in inches = Board feet in inches  
 $144 \text{ cubic inches (Volume in inches} \div 144 \text{ cubic inches} = \text{Board feet in inches)}$ .

This is the approximate total board feet in the tree. Usable or merchantable board feet is considerably less. You can get a volume table from the Forest Service. The Forest Service table gives you the volume according to the number of usable logs. Usable logs are 16 foot sections. So you would need to divide the tree height into the number of 16 ft. sections in your tree in order to use the table.

# OREGON TRAIL TEACHER'S GUIDE

## SECTION TEN - ARTS AND CRAFTS

### ART ACTIVITY SUGGESTIONS

There are many possible art activities and projects that students could perform. The following list contains just a few ideas.

1. Indian beadwork. Individual beading kits are available from the Whitman Mission site at a small cost. Beading may be a difficult project for some (suggested for intermediate-level aged children) but could be used as an optional art project or an ongoing activity with a parent/teacher helper. \*\*This project requires much patience and time.
2. Have students construct a replica of the mission using a mixture of flour, salt and water. Use tempera paint to whitewash the outside walls and green paint for trim (colors used on the original mission). The roof was made from sod--various shades of brown could be used. Models could be made to scale, thus incorporating math skills. In addition, wagons and other wooden articles could be constructed out of balsa wood, toothpicks, popsicle sticks, etc.
3. Indian Cornhusk Bag. These bags would be very difficult to accurately replicate, however, a mock cornhusk bag could be easily made by drawing patterns on colored construction paper and piecing together to make a paper "cornhusk bag." The Cayuse always used geometric shapes in their designs. Geometric designs could be used by students when designing patterns. Tempera paint, small beads, sequins, colored yarn, glitter, etc. could additionally be used to compliment this art project.
4. Make pioneer and Indian props for a play which could be performed. Possibly, get together with the school music teacher and collaborate on a project.
5. Have everyone learn the steps of some basic hand sewing/stitching. This could be accomplished by darning old socks, mending old clothes or making a simple pot holder. This project would give the students an idea of what it was like to be a pioneer, who had no electric sewing machines or much access to ready-made clothing.
6. Natural Dying. Some natural dyes could be produced by using plants native to

this area. Students could experiment with various plants that produce different colors and could learn steps necessary to extract the dye from these natural substances. Pieces of cotton fabric could then be dyed. An excellent book is available at Whitman Mission that clearly outlines the steps used in this process.

7. Have the kids make some rag dolls, similar to those that the children at the mission played with.
8. Have the students make a construction paper weaving of an Indian bag or garment. Different colored strips of construction paper can be "woven" together, creating various designs and patterns.
9. Make pencil sketches or paintings of Narcissa and Marcus Whitman. Pictures are available for kids to copy from or for the teacher to place on an opaque.
10. Make pencil sketches or paintings of Indian villages, the mission site, or of pioneers/Indians involved in activities. Drawing Indians with face paint or ceremonial clothing and decorations could be a very interesting and creative activity.
11. The interior of the Mission house is unknown as is the interior of the Cayuse lodges. Students could design possible interior plans and compare various designs.

# HOW TO BUILD A FORT

Materials needed:

- 125 popsicle sticks
- 5 toothpicks
- 1 styrofoam block (approx 6" x 12")
- brown paint/stain and green paint/stain
- Elmer's glue

1. Paint or stain 70 of the popsicle sticks brown. Then paint the styrofoam base green.
2. Following the map below, build the walls of the fort. Push the popsicle sticks deep into the styrofoam (about 1"). Remember to leave out 3 sticks for the gate.

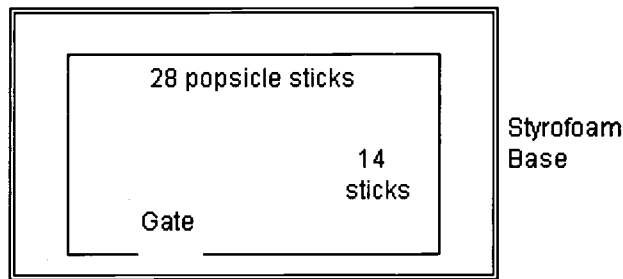

3. With the remaining unpainted popsicle sticks make the Chief Factor's house, the worker's housing, and the store.

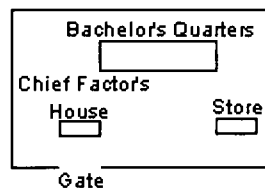

4. Color and cut out the roofs for the buildings. Glue them on top of the house walls. Color and cut out the gate, then glue it to the fort walls.

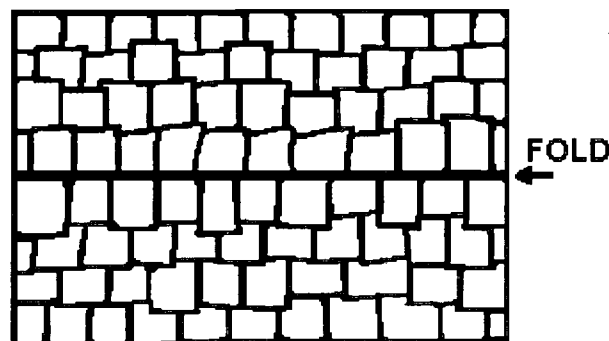

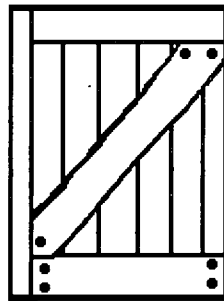
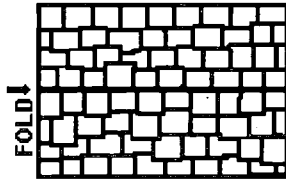
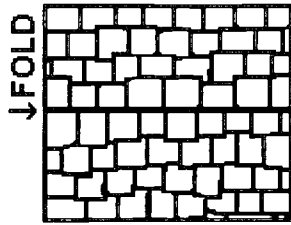

Gate



Flag

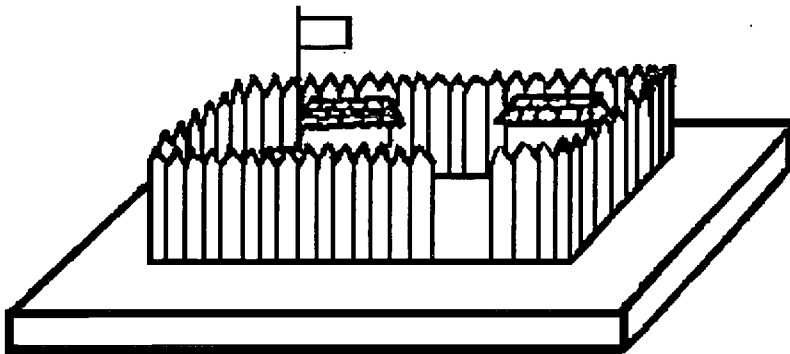

5. The last step is to make a bell tower with 3 toothpicks and a flagpole from two toothpicks. Color and cut out the flag and glue it to the flagpole.



# PAUL KANE SKETCHES

From 1845 to 1848, Paul Kane traveled throughout the western United States. His trip from Toronto to the Pacific Coast was one of the longest and adventurous sketching trips in the history of painting. Kane recorded the Native Americans in detail, their customs, homes, and ceremonies. His book "Wanderings of an Artist" is a collection of these sketches and of this romantic land. Since art is not only the creating of individual art projects but also the appreciation of others, the Paul Kane sketches should enhance your students knowledge of the art world as well as the Indian life along the Oregon Trail.

Some activities which involve the Paul Kane sketches include the following:

1. Have students study various sketches and determine if the sketches are realistic or not. What insights into Native American culture do these sketches give us?
2. Have students think of captions or small stories to go along with each sketch. Have them explain their reasoning behind their words.
3. Sketching is another form of art altogether different from painting portraits, landscapes, still lifes, etc. Have students copy these sketches, showing them how to hold and draw with a pencil.
4. As you talk about the Oregon Trail and the Native American tribes the pioneers encountered along the way, have students sketch their impressions of what these tribes may have been like. (For example, houses, daily life, attire, and living conditions.)
5. Have students sketch various scenes from their schoolyard. This would be an excellent way to teach detail, shadow, and depth perception. You might want everyone to sketch the same scene and turn it into a class project.

# CONSTRUCTING A RAFT DIORAMA

Directions: Read the instructions given below. You will also have to use the following two pages. The first page (figure 1) shows the Columbia River scene while the second page shows a raft and the foreground.

1. On figure 1, (Columbia River Gorge), color the background picture. Then cut it out and glue it to a 8 ½ x 11" sheet of paper, spreading the glue over the entire surface. Use rubber cement or glue that will not wrinkle the paper.
2. When the glue is thoroughly dry, form the diorama box by cutting and folding where indicated. Press the folds firmly so the box will keep its shape. Glue the corners of the diorama box as follows: Glue flaps one, two, three, and four on the outside of the box. Glue flaps five, six, seven, and eight on the inside of the box.
3. Color figures 2 and 3. Then glue them to a piece of lightweight cardboard. When thoroughly dry, cut out each scene as indicated.
4. Attach figure 2 as follows: Using the guide on figure 2, cut a tab from lightweight cardboard and fold one end up and one end down. Glue one end to the back of the raft. Fold back the end tabs on the back of the raft and apply glue to them, and also to the tab you attached. Insert the scene into the diorama box, holding the tabs in place with your fingers until the glue sets. You may need to use the eraser end of a pencil to hold the tabs down firmly.
5. Attach figure 3 (foreground) as follows: Fold the lines indicated. Apply glue to the inside of the tabs, then glue the tabs to the bottom and sides of the diorama box.

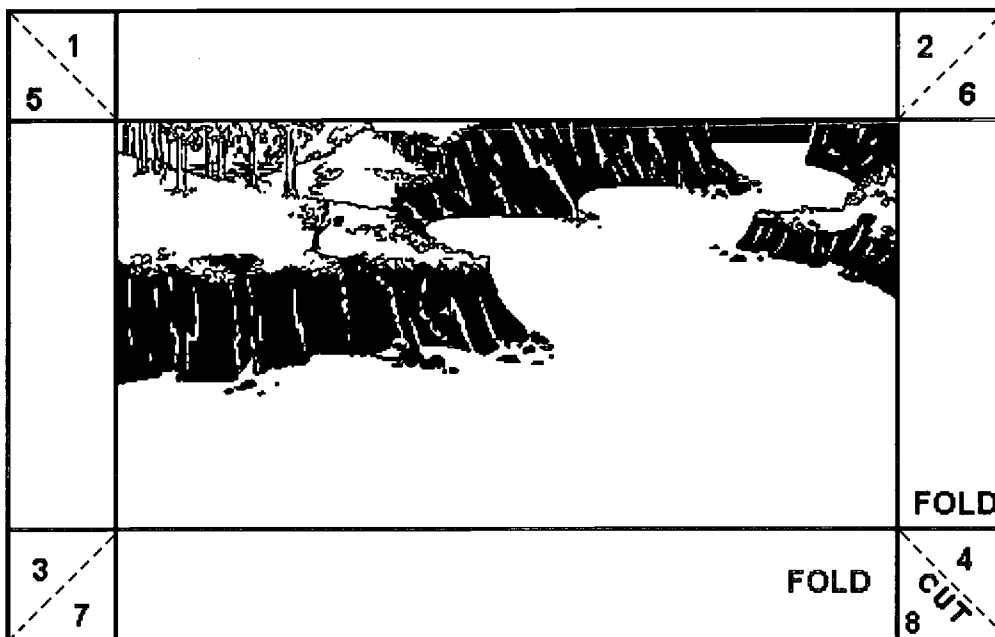

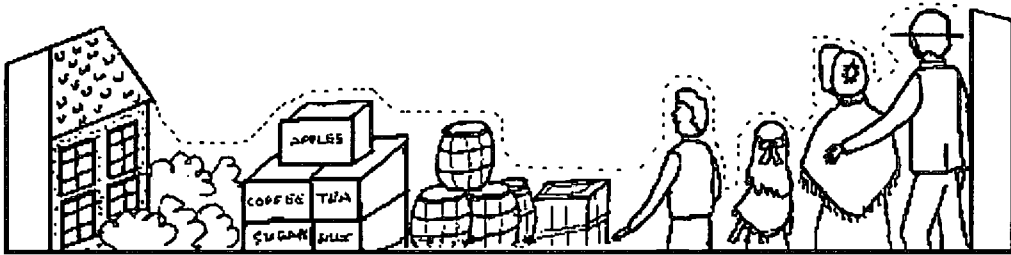
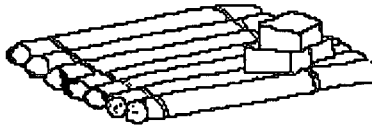

# BUILDING A COVERED WAGON #1

In this activity, students will learn how to build a model of a Prairie Schooner or Covered Wagon. These wagons were small, cramped, and very uncomfortable to live in while traveling, but models are lots of fun for students to make!!

## Materials needed:

1 milk container  
4 one-foot lengths of florist wire  
stapler  
scissors  
one 1 x 1 ½ foot piece of white muslin  
corrugated cardboard  
masking tape  
4 quarter-inch dowel sticks (2 five-inches long and 2 six-inches long)  
needle and white thread

## Procedures:

To make the BOX:

1. Cut off pouring end and one side of milk container, and lay box on its side, open side up.
2. Bend four pieces of wire into "U" shapes and staple to open sides as shown.

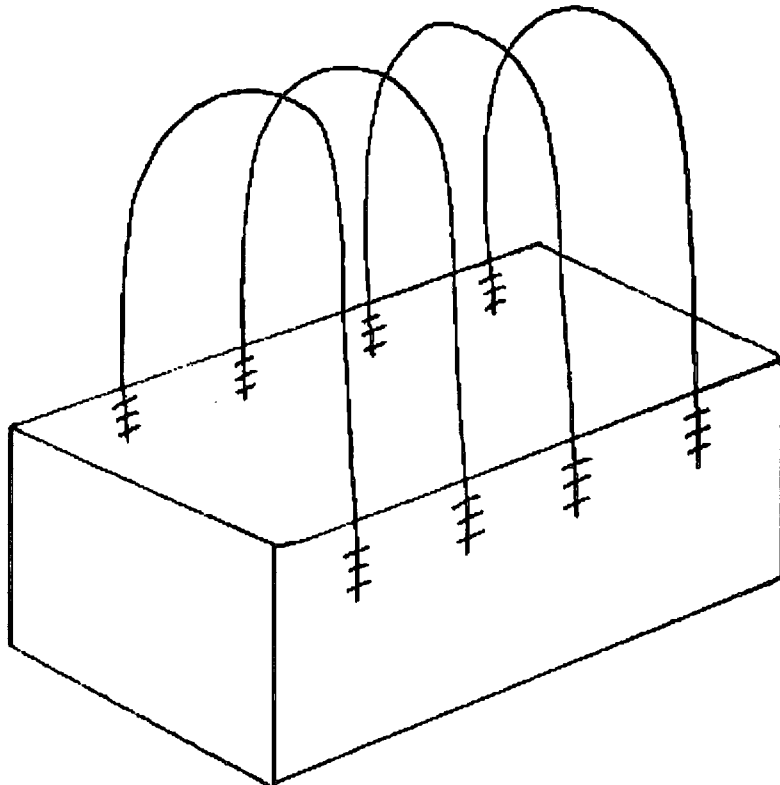

3. Place the two 6" dowels so that they are 2" apart and protrude 5" beyond the open end of the container. Tape them in place.

**To make the COVER:**

1. Lay the cloth over the wires. Sew around the wires and through the cloth so that the wires are held in place by the stitches (small stitches work best). As you go from one wire to the next, leave a bit of slack in the cloth so that it droops slightly between the wires. (Cloth can also be glued to wires.) Let ends of pieces hang as curtains in front and rear.

**To make the WHEELS and AXLES:**

1. Cut four wheels measuring 4" in diameter from the piece of corrugated cardboard.
2. Punch a hole 1/4" in diameter through the center of each wheel.
3. Paint or crayon the spokes and rim for each wheel.
4. Push dowels through 1/4" holes to make two sets of wheels. Tape the center of the dowels to the bottom of the wagon. Place one set of wheels 1 1/2" from the front and the other 1 1/2" from the rear.
5. Tape a piece of cardboard on front of the carton to close up part of front. Add a strip of cardboard for the seat.
6. Cover wagon box with brown construction paper or woodgrain, adhesive-backed vinyl.

## BUILDING A COVERED WAGON #2

1. Color your wagon cover, if you wish. All wagon covers were not white, in fact some pioneers painted their covers red, yellow, or blue. You may want to write a slogan on the cover. A slogan is something like a bumper sticker on a car. Some pioneers painted "OREGON OR BUST!" on their wagon covers, meaning they were going to try very hard to get there. Some pioneers painted their names on the wagon covers.
2. Follow the cutting out directions on the next page. These items will go into your wagon when you load it. You may also want to color these items before you cut them out.
3. Fold the page along the top of the wagon cover, matching the wheels at the top and bottom. Make a stand for the wagon as follows: Cut a strip of lightweight cardboard six inches long and one inch wide. Measure one and a half inches from each end and cut a slit halfway through the cardboard strip. Fold the strip in half lengthwise so that it stands by itself. Insert the wagon into the slits.

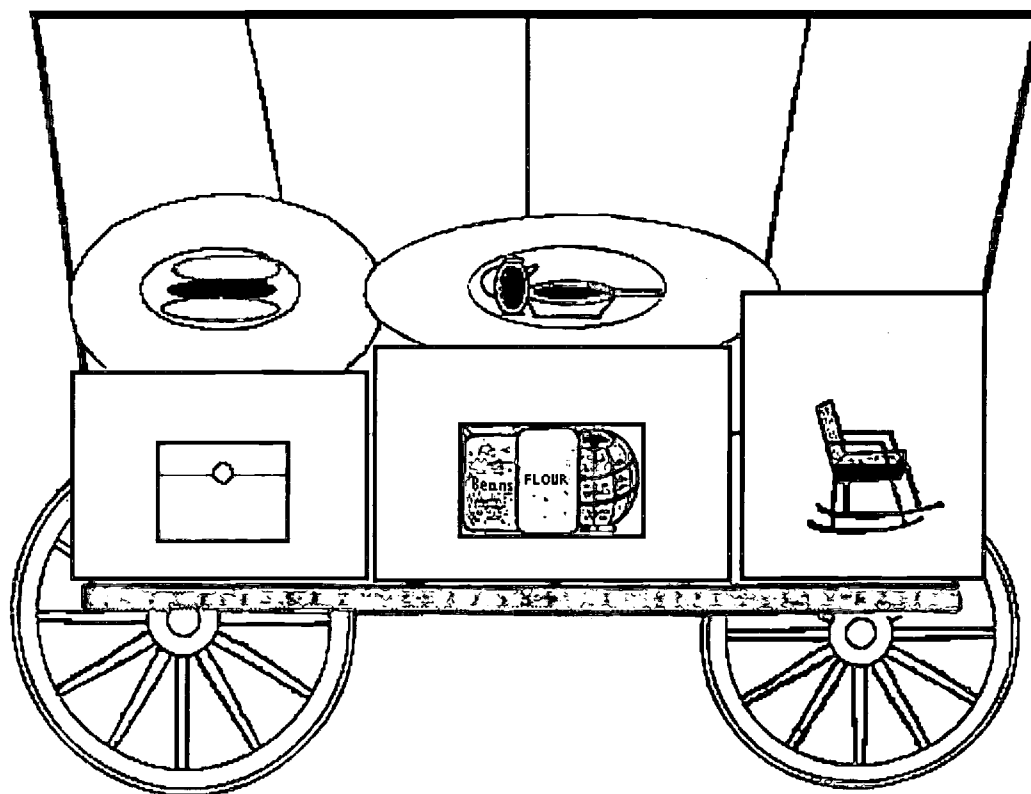

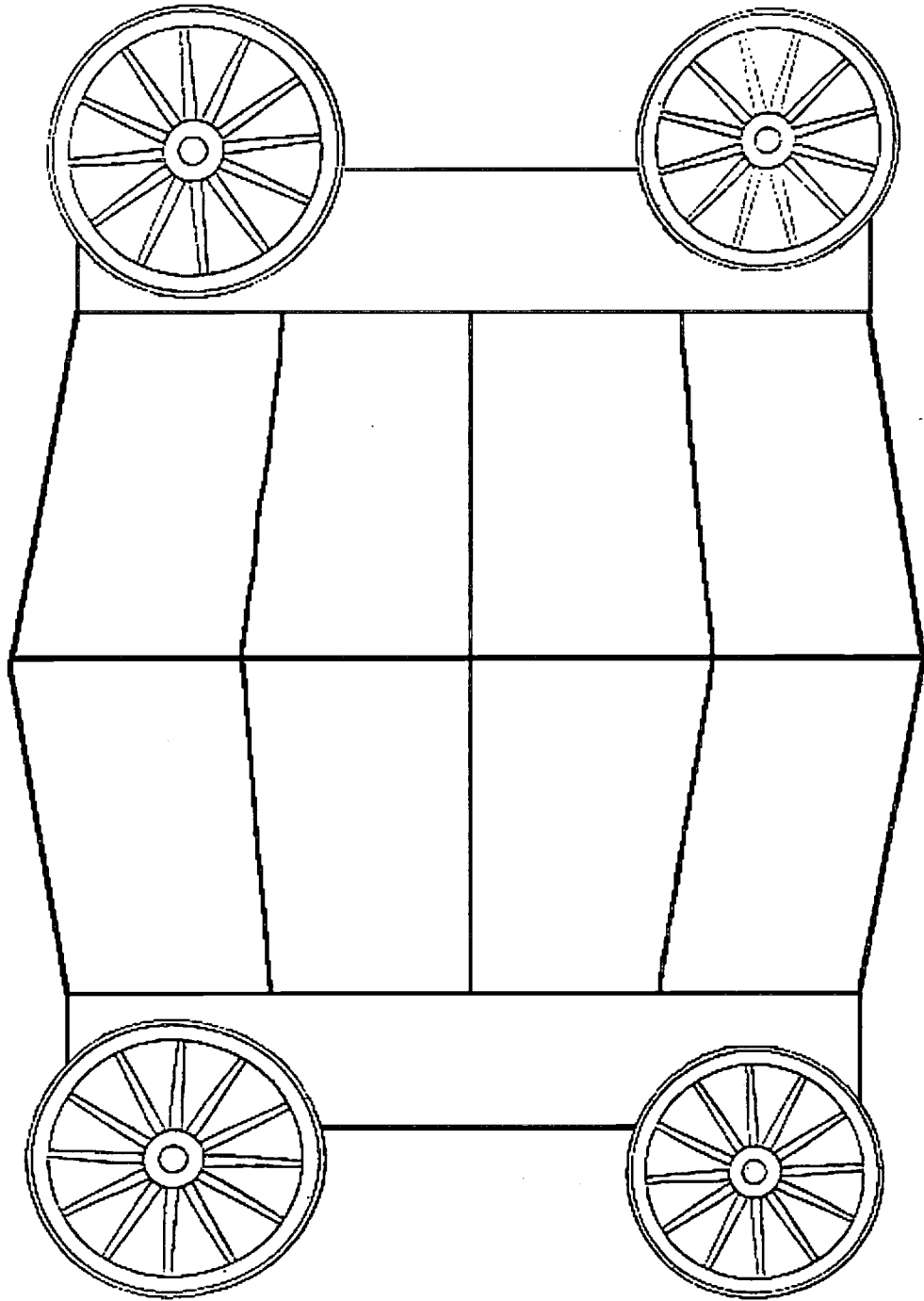

Cut out the trunk and load it into the wagon. The children's clothes are in the trunk.

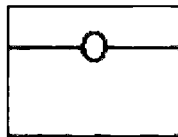

Cut out the blankets and pillows and paste them on the trunk.



Cut out the bag of flour, the bag of beans, and the barrel filled with dried fruit, sugar, coffee, and tea. Load them in the wagon.



Cut out the rocking chair and put it in the wagon for mother to rest in.

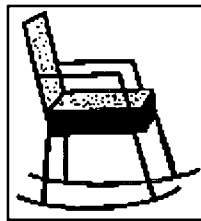

Cut out the skillet and coffee pot and place them in the wagon.





# INDIAN MOCCASINS

Directions: Run copies of the Indian moccasin on brown construction paper to resemble deer or elk hides. Follow the cut and fold directions found below. Use a hole punch to punch out the circles and use yarn or string to lace the moccasins together.

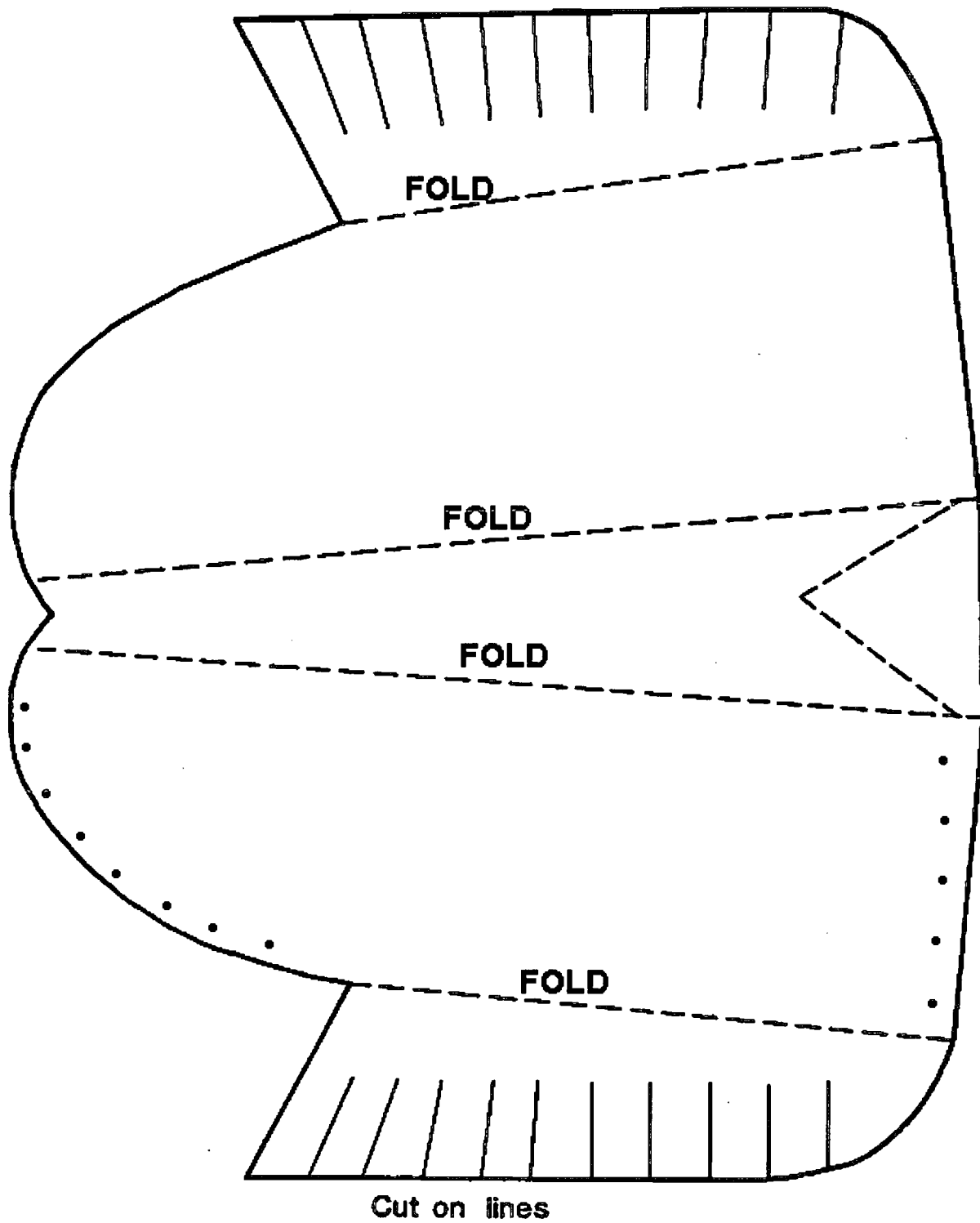

# MAKING A PATCHWORK QUILT

A patchwork quilt is a blanket or bed cover

1. A patchwork quilt is made of little patches of cloth cut in different shapes and sizes.
2. The little patches are sewed together to make a pattern. This is called a quilt block. There are many different quilt block patterns. One of the patterns on this page is a maple leaf pattern and the other is a bow tie pattern. Can you tell which is which?
3. The quilt blocks are then sewn together to make a quilt top.
4. After the quilt top is made, a layer of cotton is placed underneath to make the quilt soft and fluffy. This is the batting. Then, a large piece of cloth, the quilt lining, is placed underneath the batting.
5. Last of all, very small stitches are made around each part of the design through all three layers. This is called quilting.

# MAKE A MAPLE LEAF QUILT BLOCK

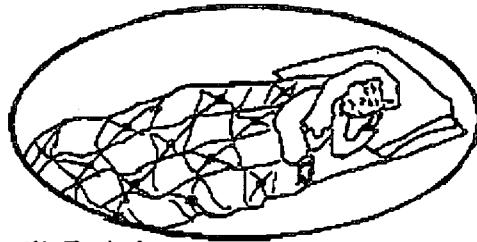

## 1. Quilt Patches

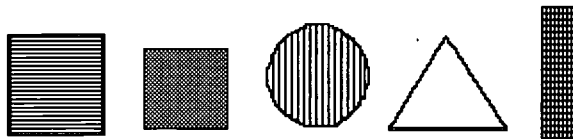

## 2. Quilt Blocks

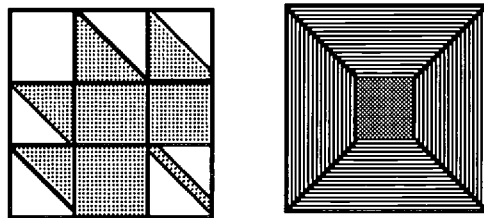

## 3. Quilt Top

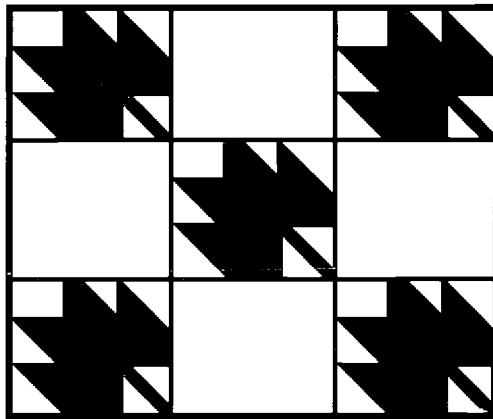

## 4. Three Layers



## 5. Quilting

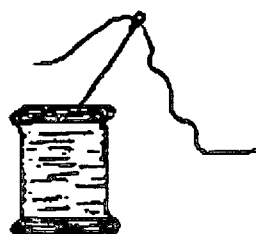
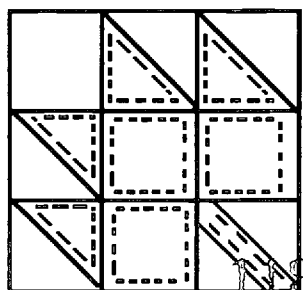

## DESIGN YOUR OWN QUILT BLOCK

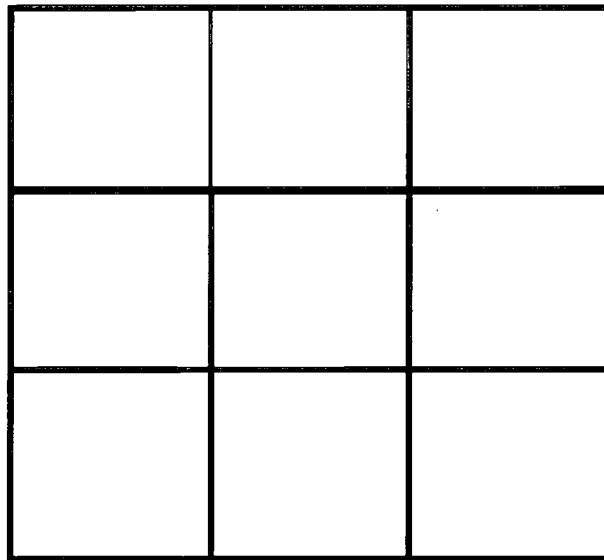

### SUGGESTIONS

1. Make different patterns by dividing the squares into triangles.
2. Make different patterns by drawing an X through each square or through some of the squares.
3. Color each patch a different color.
4. Use two colors and make a checkerboard pattern.
5. If you have a patchwork quilt at home, draw that pattern.
6. Make up your very own pattern and color it in your favorite colors.

# OREGON TRAIL TEACHER'S GUIDE

## SECTION ELEVEN - PHYSICAL EDUCATION

### TRADITIONAL GAMES

Children were active so most of their games were outdoor games and very physical. Such games included shinny, throwing pole through rolling hoop, tug of war, blind man's bluff, ball juggling, hopscotch, foot races, wrestling, swimming, etc.. Children made tops and dice out of wood and bone. They teetered on stilts, used bean shooters and flew kites. The Indians were a fun-loving people--great athletes, music lovers and tellers of tall tales. They played handball and kick ball, lacrosse, shuffleboard and quoits. They raced on foot and horse. Some games they played for fun; others were sacred and helped avert disaster or heal the sick. Shinny, ring-and-pin, and hoop-and-pole were favorite Indian games.

#### 1. SHINNY

The game is similar to field hockey, using a leather-covered ball of the same size as that used for cricket and sticks, like golf stick, but not so heavy at the turn. There are two sets of players, each of which have their own base. One on each side is selected as a mounter. He places the ball at his base, and mounts it by driving it as far as he can with a blow of his shinny stick toward the opposite base. Points are scored by driving it all the way to the opposite base.

#### 2. RING-AND-PIN

For this game, you need seven bones from the feet of deer, strung on a thirty inch thong with a bone needle tied to one end and a piece of buckskin, perforated with one large and several small holes, at the other end. Swinging the seven bones forward and up, the player tries to catch them on the needle. Or he tries to put the needle through a hole in the buckskin. Game is forty points. Threading the first bone gave the player five points, the second bone ten points, etc. The small holes in the buckskin counted four points; the large holes, nine.

#### 3. HOOP-AND-POLE

You need level ground for this game. The Indians made hoops by soaking, then bending and tying a twig or sapling into a circle twelve inches in diameter. The hoops were wrapped in buckskin. One pole or lance is needed for each player. Two at a time

compete. One rolls the hoop past his opponent who throws his spear or pole. Impaling the hoop with the spear counted one point. Seven points was game.

\*\*\*Variation: On a 100 foot long course, two players, each having a lance run side by side. One rolls a hoop ahead of them, then they both throw their spears, sliding them across the ground ahead of the hoop. The object is to stop so that it rests with one edge on the pole; this gives the player one point. If the hoop rests over the point of the pole, it scores four points or game. The point of the pole could not go through the hoop.

Indians also made darts from corncobs, feathers and sharpened sticks by placing the feather through one end of the corncob and the stick through the other.

#### 4. SNOW SNAKE

This was a favorite game played in snowy areas. The Indians would take long, smooth branches and carve snakes from them. Then a heavy log was dragged across a snow bank to make a long path. One player at a time would try to throw the snake as far as they could down the path. Sometimes players would dip their "snake" branch into water. The water would quickly freeze which would make their snake go faster and farther down the path. It was said that some Indians were capable of throwing their snake over one mile in distance.

#### 5. GUESSING GAME

This game was played by the Modoc and Klamath Indians. It was played with four sticks with the two largest sticks being painted or specially carved. One of the players would lay the sticks up and down in a row. They were then covered up with a mat or blanket for the other players to guess at the correct sequence of size. Were the larger ones on the outside or were they mixed, etc.

#### 6. BULL-ROARERS

Bull-roarers were simply thin, flat pieces of wood which could be up to two feet in length. A long rope or twine would be tied to one end of the wood and it was then swung above and around in a circle. This swinging would create a loud buzzing noise. In some native American cultures bull-roarers were thought of as having magical powers that could control the wind. Because of the magical powers that the pieces of wood possessed, Indian children, in those cultures, were not allowed to play with the bull-roarers.

# OREGON TRAIL TEACHER'S GUIDE

## SECTION TWELVE - APPENDIX

### Pioneer and Indian Recipes

#### **Hardbread Biscuits:**

You will need:

2 cups stone ground flour  
1 cup water

Combine the flour and water. Knead until smooth. Sprinkle some flour on a smooth surface and roll the dough flat until it is 1/4 inch thick. Cut biscuits out with a can or a glass making each biscuit about 3-4 inches in diameter. Poke holes into each biscuit with a fork. Place on a floured cookie sheet.

Oven: 400 F  
Time: 35-45 minutes  
Yield: 12-15 biscuits

#### **Beef Jerky:**

You will need:

1 flank or London broil steak (or other very lean cut of meat)  
salt and pepper  
1 cup soy sauce  
aluminum foil

Cut the steak into strips with the grain of the meat. It is very important to cut along the grain or the cooked meat will fall apart into small pieces! Pour the soy sauce into a bowl and dip the meat strips in it. Lay the strips out on a piece of foil and sprinkle generously with salt and pepper on both sides. Place the strips on a metal rack in the oven with foil below to catch the drippings.

Oven: 150 F  
Time: 10 hours

**\*\* You can put your beef jerky in the oven at bedtime and it will be ready to take out in the morning before school.**

### **Indian Fry Bread:**

You will need:

3 cups self-rising flour  
2/3 cup powdered sugar  
1/3 cup milk  
1 cup cold water  
corn oil (for frying)

In a bowl, mix sugar and milk. Gradually stir in the water until the flour is moistened and the dough forms. Turn the dough out on a lightly floured surface; knead until dough is well mixed. Roll to a 10 inch square and about ½ inch thickness. Cut into 12 rectangles. In a deep saucepan, heat some oil at 375 F. and fry the dough 2-3 minutes or until medium brown. Turn often as you are frying. Drain on a paper towel and sprinkle with powdered sugar.

### **Narcissa's Camp Bread:**

You will need:

1 cup flour  
½ cup water  
shortening (for frying)

Mix the water and the flour together. Stir and knead to form a dough free from lumps. Turn this onto a lightly floured board and pat into a rough square about ½ inch thick. Cut this into about 2 inch squares. Melt shortening in a heavy skillet. (Be sure to use enough shortening to give the bottom of the skillet a good coating.) When a drop of water sizzles in the pan, place the dough squares into the shortening. Cook the squares at a medium heat until lightly browned. Then turn over and cook the other side as well. Serve at once.

**\*\*The addition of 1 ½ teaspoons of baking powder and ½ teaspoon of salt will give our modern tastes a more palatable product.**

### **Sarah Smith's Meat Pies:**

You will need:

1 pound ground beef  
salt and pepper  
2 pie crusts



Cook ground beef, breaking it apart as it cooks, until it starts to lose its red color. Salt and pepper to your taste. Make your favorite pastry and divide it into two parts. Roll each part into a circle about 10 inches in diameter and place this on a baking sheet. Spoon one half of the meat mixture over one half of each circle, leaving about a 1 inch border around the edge. Moisten the edge of pastry with water, fold the unfilled half over filling, and press edges together to seal. Then cut 3-4 slits into the top to allow the steam to escape. Repeat this process with the other pastry.

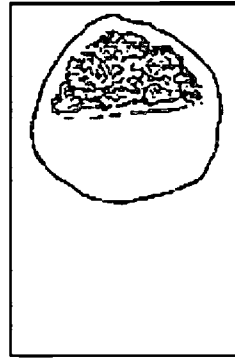

Figure 1

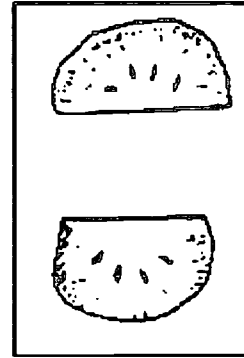

Figure 2

Oven: 350 F

Time: 20 minutes (or until nicely browned)

### **Sarah Smith's Buffalo Gravy:**

You will need:

- 1 lb. ground beef
- 4 Tbs. flour
- salt and pepper
- 2 cups milk

In a heavy skillet or dutch oven, brown ground beef, breaking it apart into chunks as it cooks. Cook until the meat loses its red color, and add salt or pepper as desired. Stir in 4 tablespoons of flour. Stir constantly, and then add 2 cups of milk. Cook until thickened. If it becomes too thick, you may add a little more milk. Adjust the seasoning if necessary. You might want to try this over a baked potato or biscuits. Should serve about four.

### **Tea Biscuits:**

You will need:

- 1 cup butter
- 1 cup milk
- 4 eggs
- 3 cups flour
- 1 tsp. salt
- 1 ½ tsp. baking soda
- 2 tsp. cream of tartar

Mix all ingredients together. Make into a thin loaf and bake in flat, greased pan. Break into chunks. Serve warm with butter and honey.

Oven: 350 F

Time: 30 minutes (check after 20 min.)

### **Potato Pudding:**

You will need:

3 large potatoes

3 eggs (separated)

1 cup granulated sugar

1/4 cup flour

1 tsp. salt

1 cup cream

1/2 fresh lemon (juice squeezed, and rind grated)

Boil, mash and cool the potatoes. Mix with egg yolks. When well blended, add egg whites, (which have been well beaten and combined with sugar) flour, salt, cream, and lemon, juice and grated rind. Bake in a buttered dish until firm. Serve with sugar and cream. Also, they are good when they are topped with fresh berries, sweetened and crushed.

Oven: 350 F

Time: 30 minutes (or until firm)

### **Apple Treat:**

You will need the following:

4-5 slices of buttered bread

1 can sweetened apple sauce

2 eggs

1 pint milk

1/2 cup granulated sugar

1/2 tsp. salt

Line the bottom of a pudding dish with buttered bread and cover with apple sauce. Repeat until dish is half-full, finishing the layering with the bread on top. Mix eggs, milk, sugar, and salt. Pour this mixture over bread and sauce. Bake until set. Serve cold with cream, sugar, and nutmeg gratings or cinnamon.

Oven: 350 F

Time: Approx. 25 minutes

### **Apple Snow:**

You will need: 10 apples  
1 cup water  
Grated rind of 1 lemon  
10 eggs (separated)  
1 cup granulated sugar

Peel and core apples. Simmer in water with lemon rind until tender. Put through colander and cool. Take egg whites, beat to a stiff froth, and fold into apples. Add sugar, and continue beating until stiff. Serve in a glass dish with either custard sauce made with the egg yolks, or whipped cream. This is good enough for a party when served with ladyfingers, snow cake, or sponge cake.

### **Cranberry-Nut Muffins:**

You will need the following:

1/4 cup margarine  
1/2 cup honey  
2 beaten eggs  
1/2 cup orange juice  
1 1/2 cups flour  
1 tsp. grated orange rind  
1 tsp. baking powder  
1 1/2 tsp. salt  
3/4 cup chopped cranberries  
1/2 cup chopped walnuts

Cream margarine and honey. Add the eggs, orange juice, and rind. Mix in the flour, baking powder, and salt. Then, add the cranberries and the walnuts. Bake in oiled muffin tin.

Oven: 350 F  
Time: 35 minutes

## Oregon Trail Books

TITLE	AUTHOR	COST	CLASSROOM USE
Wagon Trail Travels	T. Farnham	\$3.00	Morning Diary/Seat work
The Plains Across	John D. Unruh, Jr.	\$19.95	Reading/Reference
Oregon Trail Dangers and Dreams	Jane Kurtz	\$3.75	Various Activities and Indian Chief's names
Chief Joseph Country	Gulick	\$39.95	Reading/Reference
The Cayuse Indians	Ruby & Brown	\$9.95	Indian Names/History
Coyote Was Going There	Jarold Ramsey	\$17.95	Reading/Writing
Cobblestone Magazine - The Oregon Trail		\$4.50	Class reading
Historic Sites Along the Oregon Trail	Aubrey Haines	\$16.95	Reference
Cooking the Dutch Oven Way	Woody Woodruff	\$11.95	Reference
The Prairie Traveler	Randolph B. Marcy	\$10.95	Oregon Trail info.
Oregon Trail -- Voyage of Discovery	KC Publications	\$7.95	The story behind the Oregon Trail
Stout Hearted Seven	Neta Lohnes Frazier	\$4.95	Classroom Reading/Writing
The American Frugal Housewife	Lydia Child	\$9.95	Pioneer Cooking and Homemaking
Old Oregon Trail Map		\$ .93	Reference
Video -- Story of the Oregon Trail		\$19.95	Oregon Trail info.

The above books and others can be found at our bookstore on the web or the Whitman Mission Museum. It would be helpful to have these books on hand for reference purposes. Many of the books can be read by your students and will provide ideas for them to write their own legends and pioneer stories.

An order form may also be obtained by calling (509)522-6360 or writing:

Whitman Mission National Historic Site  
 Rt.#2, Box 247  
 Walla Walla, WA 99362

# AUDIO-VISUALS AVAILABLE FOR LOAN TO SCHOOL GROUPS - 16 MM/SOUND AND ½" VHS VIDEO CASSETTE

TITLE	LENGTH	DESCRIPTION
THE WHITMANS AND WAILLATPUS	14 Minutes	The story of Whitman Mission and the Waiilatpu Indians as seen through the eyes of children. Although designed for children, the film has been well received by adults. It deals with the major significance of the Waiilatpu area.
A MEMORY RETRIEVED	10 minutes	A film detailing the construction of the covered wagon which is displayed at the Whitman Mission National Historic Site
JOURNALS OF LEWIS & CLARK	27 minutes	This film tells the story of the Lewis & Clark expedition which began near St. Louis in 1804 and follows them until they reach the Pacific Ocean in 1805. An excellent movie for groups studying Northwest History.
ECHOES OF THE PAST	20 minutes	Documents Nez Perce culture, past and present
LAST SALMON FEAST OF THE CELILO'S	17 minutes	This film documents the last Salmon feast held before Celilo Falls was covered by water backed up by The Dalles Dam
PORTRAIT OF A PEOPLE	15 minutes	Official park film of the Nez Perce National Historic Park
THE OREGON TRAIL	32 minutes	Video describing what people saw as they crossed the most famous trail.
THE PONY EXPRESS	16 minutes	The story about the Pony Express.

**\*\* In order to request films, please write to the following address:**

Whitman Mission National Historic Site  
 Route 2 Box 247  
 Walla Walla, WA 99362  
 If you wish to call, our phone number is (509) 522-6360

# ORGANIZATIONS AND AGENCIES ALONG THE OREGON TRAIL

## IDAHO

Idaho Department of Commerce  
700 W. State Street  
Boise, Idaho 83720  
(208) 334-2470  
1-800-635-7820

Millner Interpretive Site  
Bureau of Land Management  
Burley Field Office  
15 East 200 South  
Burley, Idaho 83318  
(208) 678-5514

Three Island Crossing Parks  
P.O. Box 609  
Glens Ferry, Idaho 83623  
(208) 366-2394

Old Fort Boise Replica  
Parma, Idaho 83660  
(208) 722-7608

Idaho State Historical Society  
210 Main  
Boise, Idaho 83702  
(208) 334-3890

Massacre Rocks State Park  
HC76, Box 1000  
3592 N. Park Lane American Falls, Idaho 83211  
(208) 548-2672  
(208) 548-2472

Fort Hall Replica  
Alvord Loop (In Ross Park)  
Pocatello, Idaho 83205  
(208) 234-6232

## WASHINGTON

Washington State Historical Society  
1911 Pacific Ave.  
Tacoma, Washington 98402  
(253) 272-3500

Ezra Meeker Mansion  
P.O. Box 103  
Puyallup, Washington 98371  
(253) 848-1770

Fort Vancouver National Historic Site  
612 East Reserve Street  
Vancouver, Washington 98661  
(360) 696-7655

Whitman Mission National Historic Site  
Route 2, Box 247  
Walla Walla, Washington 99362  
(509) 522-6360

## OREGON

Oregon Tourism Division  
775 Summer Street N.E.  
Salem, Oregon 97310  
1-800-547-7842

Oregon Historical Society  
1200 S.W. Park Avenue  
Portland, Oregon 97205  
(503) 306-5280

Four Mile Canyon Interpretive Site  
P.O. Box 2965  
Portland, Oregon 97208  
(503) 280-7001

Alkali Springs Interpretive Site  
Bureau of Land Management  
Vale District  
100 Oregon St.  
Vale, OR 97918  
(541) 473-3144

Birch Creek Interpretive Site  
Bureau of Land Management - Vale District  
100 Oregon St.  
Vale, OR 97918  
(541) 473-3144

Keeney Pass Interpretive Wayside  
Bureau of Land Management  
Vale District  
100 Oregon St.  
Vale, OR 97918  
(541) 473-3144

Echo Meadows Interpretive Site  
Bureau of Land Management - Baker Resource Area  
3165 10th St.  
Baker City, OR 97814 (541) 523-1353

McLoughlin House  
National Historic Site  
713 Center Street  
Oregon City, Oregon 97045  
(503) 656-5146

End Of Trail Interpretive Center  
500 Washington  
Oregon City, Oregon 97045  
(503) 657-9336

Oregon Trail Interpretive Center  
Flagstaff Hill  
Baker City, Oregon  
(541) 523-1843

John Day River Crossing  
Interpretive Site  
P.O. Box 2965  
Portland, Oregon 97208  
(503) 280-7001

Barlow Road  
Bear Springs Work Station  
Barlow Ranger District  
73558 Highway 216  
Maupin, Oregon 97037  
(541) 328-6211



Columbia River Gorge National Scenic Area  
902 Wasco Avenue  
Waucoma Center, Oregon 97031  
(541) 386-2333

Emigrant Springs State Park  
P.O. Box 85  
65086 Old Oregon Trail  
Meacham, Oregon 97859  
(541) 983-2277

Deschutes River State Park  
89600 Biggs-Rufus Highway  
Wasco, Oregon 97065  
(541) 739-2322

Farewell Bend State Park  
Star Route  
Huntington, Oregon 97907  
(541) 869-2365

Blue Mountain Crossing Interpretive Center  
La Grande Ranger District  
3502 Highway 30  
La Grande, Oregon 97850  
(541) 963-7186

Tamastlikt Cultural Institute  
P.O. Box 638  
Pendleton, Oregon 97801  
(541) 276-3873

Gorge Discovery Center  
P.O. Box 342  
The Dalles, Oregon 97058  
(503) 296-8600

End Of The Oregon Trail Interpretive Center  
1726 Washington  
Oregon City, Oregon 97045  
(593) 557-8542 (Group info.)  
(503) 657-9336

# TEACHER'S GUIDE EVALUATION FORM

We would appreciate it if you would take the time and evaluate the teacher's guide. Since this will be updated periodically, your suggestions and comments would be very helpful. Please take into consideration that this guide is directed towards all grade levels.

I am evaluating:

\_\_\_\_\_ Whitman Mission Teacher's Guide

\_\_\_\_\_ Oregon Trail Teacher's Guide

Circle the appropriate number with a "5" being excellent

1 2 3 4 5 General layout of guide contents (Readability and easy access to information)

1 2 3 4 5 Historical information presented clearly

1 2 3 4 5 Amount of historical information given

1 2 3 4 5 Classroom activities presented clearly

1 2 3 4 5 Classroom activities practical

1 2 3 4 5 Number of classroom activities included is adequate to support units

1. Grade level taught \_\_\_\_\_

2. Do you feel that the guide is appropriate for your grade level?

---

---

3. Is there any historical information which you feel is incomplete or not given?

---

---

4. Did you base your total curriculum around the Whitman Mission theme or were you only involved with particular sections of it? Please explain.

---

---

5. Which sections did you find to be the most/least useful? Why?

---

---

---

---

6. Which classroom activities did you utilize & how would you rate them?

---

---

---

7. Do you have any suggestions for additional classroom activities?

---

---

---

8. Additional comments.....

---

---

---

---

Please mail your evaluation form to:

Whitman Mission National Historic Site  
Route 2 Box 247  
Walla Walla, WA 99362

Thank you,

Whitman Mission Park Rangers



*U.S. Department of Education*  
*Office of Educational Research and Improvement (OERI)*  
*National Library of Education (NLE)*  
*Educational Resources Information Center (ERIC)*



## NOTICE

### REPRODUCTION BASIS



This document is covered by a signed "Reproduction Release (Blanket) form (on file within the ERIC system), encompassing all or classes of documents from its source organization and, therefore, does not require a "Specific Document" Release form.



This document is Federally-funded, or carries its own permission to reproduce, or is otherwise in the public domain and, therefore, may be reproduced by ERIC without a signed Reproduction Release form (either "Specific Document" or "Blanket").